

## HEPA Filter System with Scanner, Type SCF<sub>hightec</sub> Triple S



**HEPA Filter System with Scanner,  
Type SCF<sub>hightec Triple S</sub>**

Krantz HEPA filter system, type SCF<sub>hightec Triple S</sub> are used in BSL 3 and 4 class laboratories. The design considers the applicable rules like:

- „Laboratory biosafety manual“ by World Health Organisation (WHO),
- „Biosafety in Microbiological and Biomedical Laboratories“ (BMBL) as well as
- EN 12 128 “Biotechnology – Laboratories for research, development and analysis – containment levels of microbiology laboratories, areas of risk, localities and physical safety requirements“



HEPA filter system, type SCF<sub>hightec Triple S</sub> with pre-filters and two stages of HEPA filters H14

Mobile scanning device for online efficiency measurement of HEPA filters

**Housing**

Robust filter housing made of stainless steel, material 1.4301 (AISI/SAE 304) in gastight design according to the tightness requirements of the DIN 25 496, table 3, for fine-dust and HEPA filter elements, the insertion ports are clearly marked.

To ensure good results in disinfection and decontamination the housings are welded continuously and without gaps. To make transport easier the housings are provided with lugs.

The filter housing is placed on the floor with its integrated support made from 1.4301. So an exchange of filters in optimal working height is provided. The support shall be bolted to the floor. wird im Boden verschraubt.

**EH – Analysis (option)**

An EH – analysis (EH = External Hazard) can be provided in form of an FEM-calculation to proof the safety in case of e.g. earthquake. The results will be considered in the design of the housing, the support and the anchoring to the floor. The load cases for the building will be mentioned.

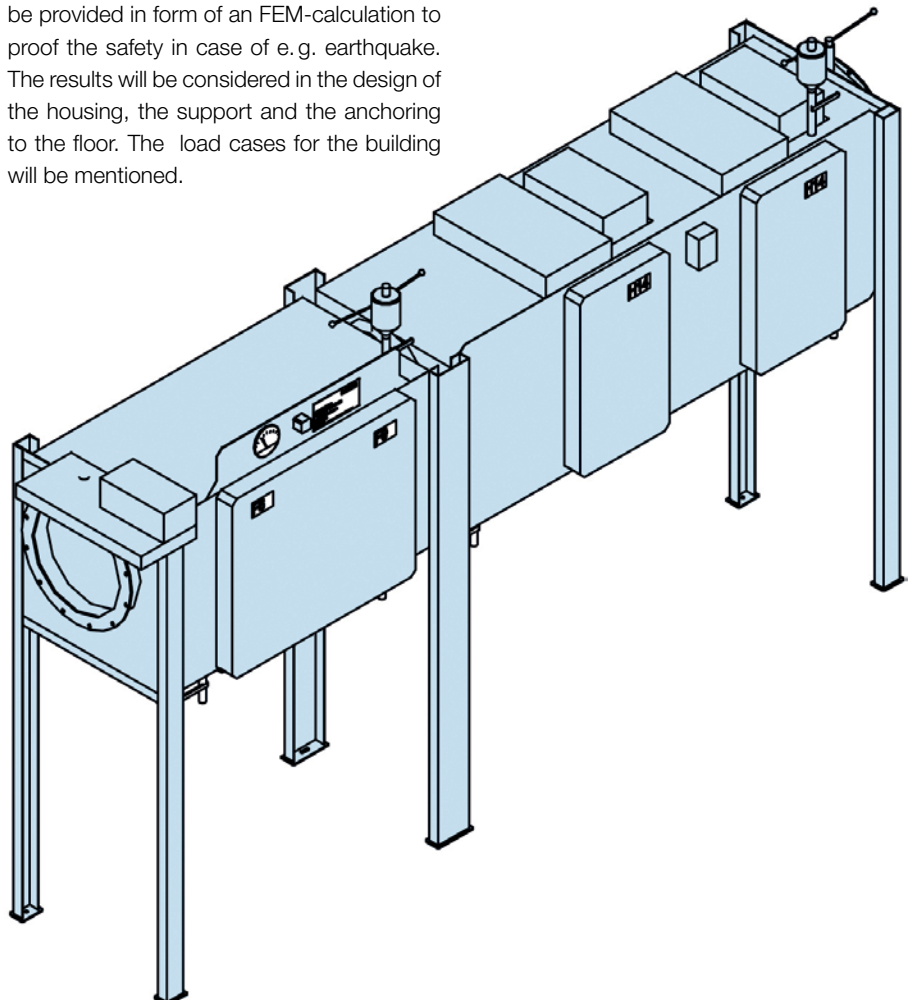

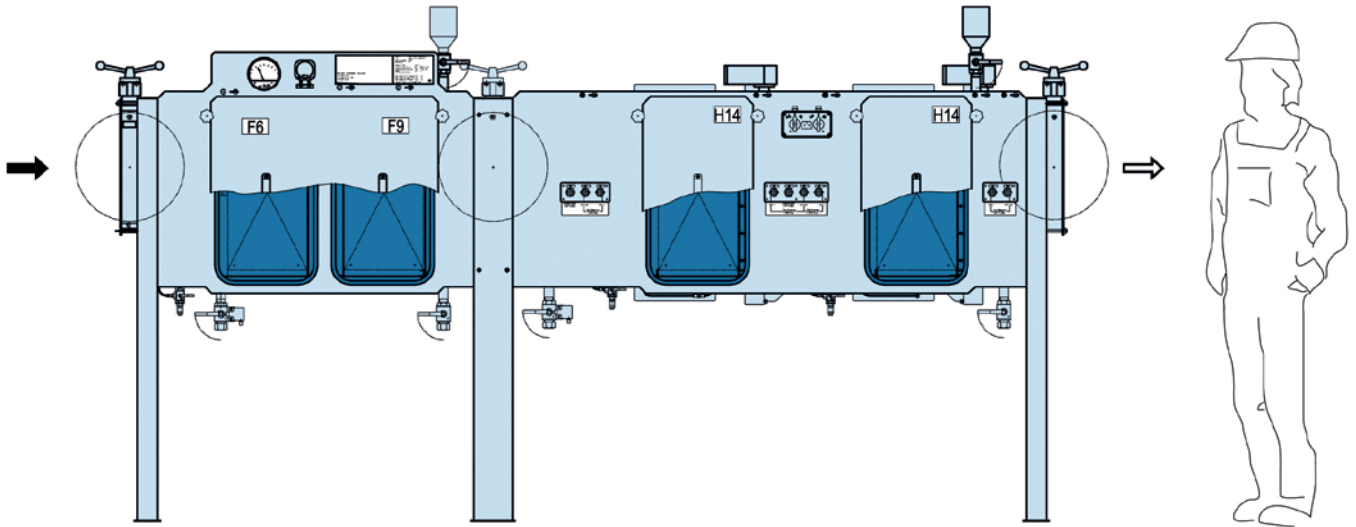

SCF<sub>hightec Triple S</sub> with separate pre-filter and HEPA filter stage including gastight dampers in front of filter housing, between pre-filter and HEPA filter stages and behind filter housing

### Sealing of filter elements

Clamping of the HEPA filter elements by means of self-adjusting spring systems, to ensure the tightness requirements for the seat of the filter element according to DIN 25 496, table 3, under conditions of a retreating sealing caused by e. g. aging.

Quick release of the clamping devices by means of single acting pneumatic cylinders for filter element exchange. The cylinders to be supplied with compressed air (6 bar oil-free and waterless) via a three-way valve positioned at the front side of the filter housing. So for the inflating and also for the deflating of the cylinders the air is always released into the filter housing safely.

The clamping devices of the HEPA filter elements are operated from outside and designed to ensure the tightness requirements for the seat of the filter element according to DIN 25 496, table 3, under conditions of maximum loading of the filter elements and a retreating sealing.

Test grooves according to DIN 1946-4 and DIN 25 414 resp. for the HEPA filter elements made of stainless steel. In order to proof the leak free seat of the filter elements the test groove can be connected to a leak test device (see accessories) via fast acting cou-

pling, positioned at the front side on the filter housing.

Each filter element is sealed to the housing on both sides using the 3-seal concept (Triple S) so that the barrier from the inside to the outside of the filter housing remains intact even if the maintenance cover is removed.

### Inserting and changing of filter elements

The fixture for the fine dust and the HEPA filter elements is available in horizontal and vertical design. An arbitrary air flow direction horizontal or vertical is possible on the raw air and on the clean air side on demand. Each filter line is equipped with a separate insertion port with a special collar so that the changing of the filter elements using the bag in bag out method without contaminating the environment is possible. The special collar has two circumferential sealing grooves according to DIN 25 466, supp. 1, to take the hollow rubber band for the plastic bag fixation. Undercut groove with perfectly matched hollow rubber band to ensure a gastight seat of the plastic bag. The special collar, the maintenance bags and the internal parts of the filter clamping device are protected by a mainte-

nance cover from 1.4301 which is bolted to the filter housing by 4 hand screws.

The housing is equipped with a bleed filter device consisting of a gas tight ball cock and an ULPA-Filter U 15.



Special collars with sealing grooves acc. to DIN 25 466 supp. 1 ensure gastight seat of the plastic bag for safe bag-in bag-out changing of filter elements

### Indication of filter loading

To monitor the filter loading each filter stage can be equipped with a Magnehelic® differential pressure gauge, (optional with signal transmitter) instrument holders, connections and connecting lines optional from stainless steel or nickel coated brass.

The inlet and outlet side of the pressure monitoring line are completed with a ball cock (optional from stainless steel or nickel coated brass) and U15-filter each. Additionally the measuring line is equipped with a disinfection connection.



Magnehelic® differential pressure gauge for indication of filter loading

### Raw and clean air spigots

The filter housing is equipped with one raw air and one clean air spigot made from 1.4301 in leak tight design. The spigots are designed as even closure, bolted to the filter housing by a circumferential rim and silicon gaskets. Welded to the spigots is a circular adapter for a gastight damper. A perforated plate is arranged in the air inlet to ensure an uniform loading of the filter stages.

### Gas tight damper

Gas tight dampers are installed on the raw air and the clean air side of the filter housing. The dampers are equipped with a test groove to proof the damper seat tightness in operation.

### Spreading of contamination

Each connection is secured twice against spreading of contamination to the outside. For that purpose each particle measuring line is equipped with manual operated ball cocks and fast acting couplings suited for disinfection and decontamination. Both can be made from stainless steel or nickel coated brass on request.

### Disinfection and decontamination

The filter housing is equipped with disinfection nozzles. Additionally the ball cock on the disinfection inlet nozzle is equipped with a limit switch which, due to safety reasons, only unlocks the disinfection device connected to it once the ball cock is in "open" position. Also all other connections are provided with a gassing option sealed with ball cocks and locking cups.

Gassing is possible once the filter elements are released (not clamped) so that the filter elements and the sealing are flushed during disinfection. The disinfection concept is configured for formalin disinfection. Alternatively hydrogen peroxide or  $\text{CH}_3\text{COOH}$  may be used.

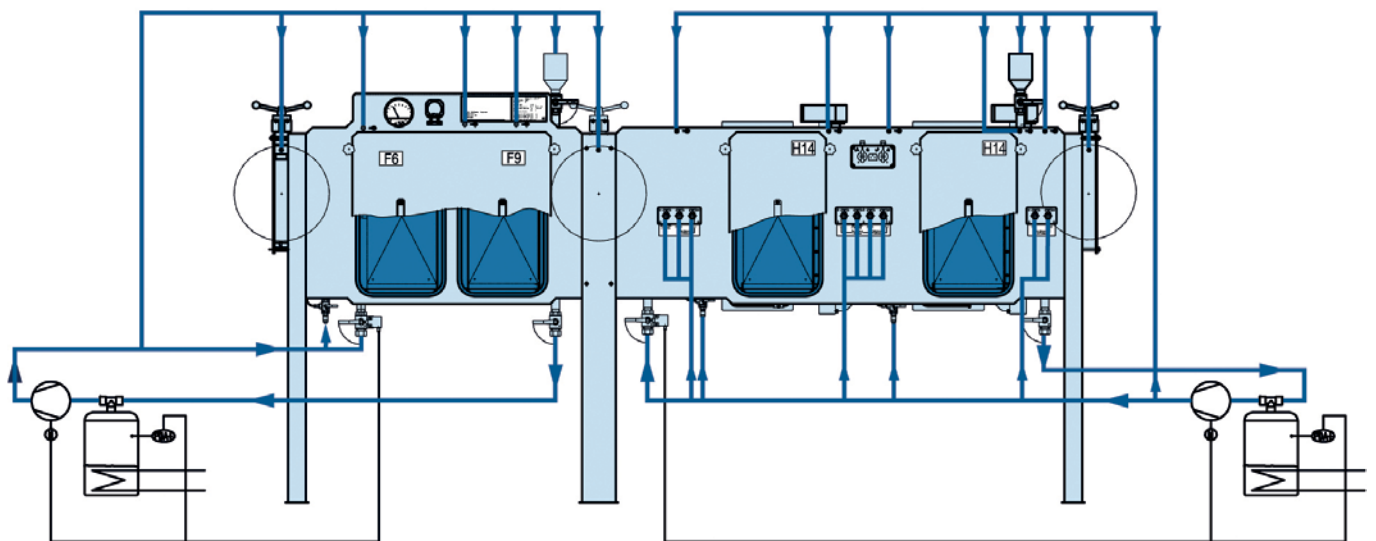

Disinfection of filter housing and all connectors

### Scanner

The filter housing is equipped with a fully automatic scanner behind each HEPA filter stage. The special engineered and patented scanner bar allows the filter elements to be efficiency checked in operation. All measuring lines are optional from stainless steel or nickel coated brass. They are led through gas tight housing penetrations and can be connected to the mobile filter efficiency test rack. The scanner bar is actuated by an electrical motor installed outside the housing and protected by a maintenance cover.

The limit switches are installed outside the filter housing and accessible for service without opening the filter housing. After particle counting the used air is led back to the air inlet side of the filter stage inside the filter housing.

The aerosol feeding probe in front of the HEPA filter stage is designed as manifold tube with holes. Additionally in front and behind the HEPA filter stage extracting probes are installed. All probes are lead to the outside of the filter housing with a ball cock and a fast acting coupling, optional from stainless steel or nickel coated brass.



Connectors for aerosol feeding and extracting

### Feeding particles for detection and mobile test rack

To perform the filter inspection during operation two mobile test racks are connected to the filter. In the first rack all devices for measuring particle feeding (compressor, aerosol generator and mixing box) are installed. This is connected to the particle feeding probe in the filter housing.

The second rack contains the diluting stages, the optical particle counters (OPC) for the raw air and for the clean air side as well as the computer for the automatic control of the scanning process and the evaluation of the results.



Mobile test rack for scanning device

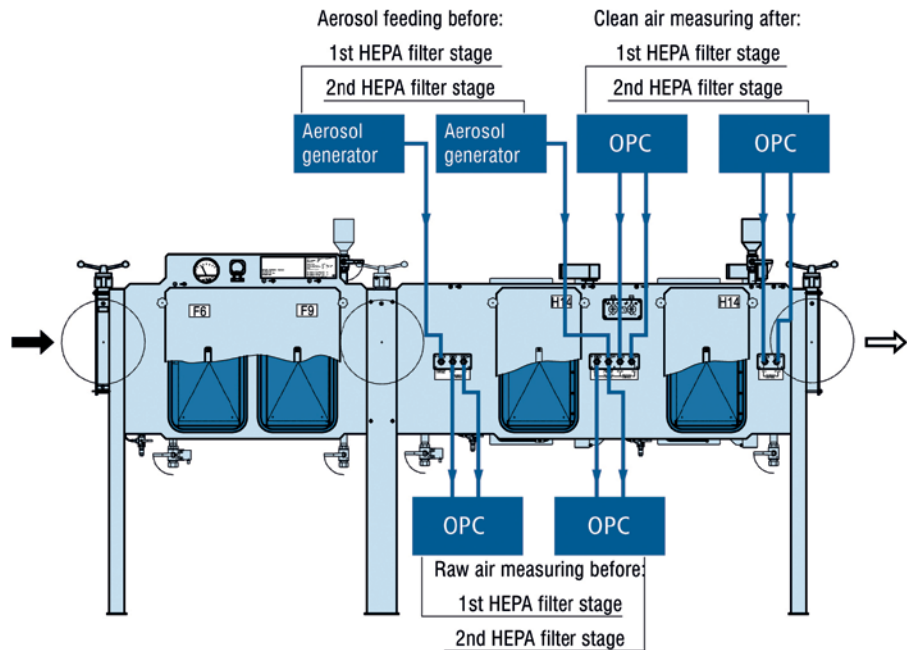

Principle of automatic efficiency measurement



**Principle drawing of the HEPA filter stage**

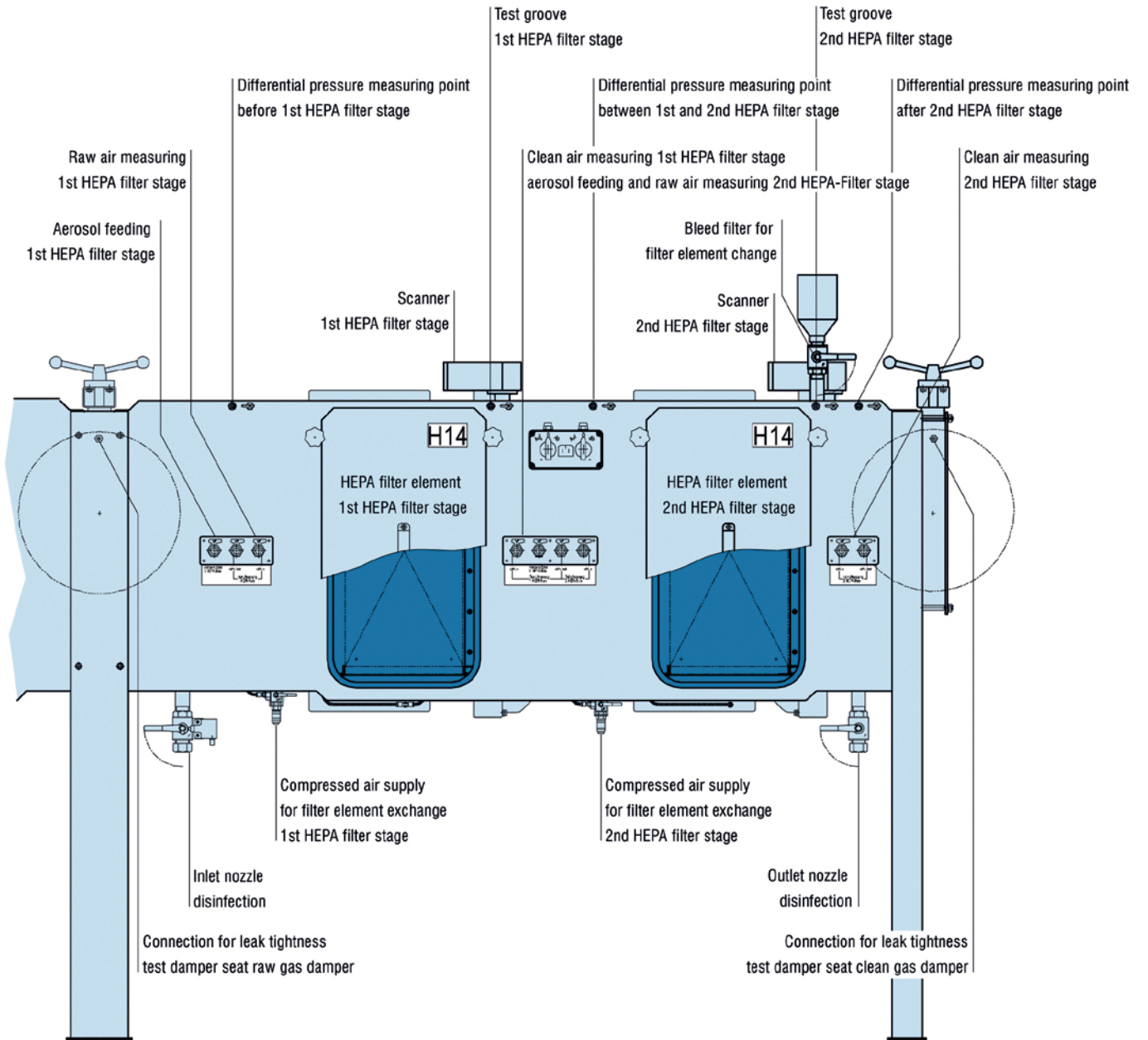

## Text for tender

### HEPA filter system with scanner, type SCF<sub>hightec Triple S</sub>

- Robust filter housing made of stainless steel, material 1.4301 (AISI/SAE 304) in gas-tight design according to the tightness requirements of the DIN 25 496, table 3, for fine-dust and HEPA filter elements, the insertion ports are clearly marked.
- All welding are made according to DIN 25 496, item 6.2(4), that means using stabilised steel at austenitic material, e. g. material 1.4541 (AISI/SAE 321 or B.S. 321 S12) and using killed steel at ferretic material.
- To ensure a good decontamination and disinfection result housing welds are continuous and without gaps.
- The housing is equipped with lifting lugs for easy handling.
- Clamping of the HEPA filter elements by means of self-adjusting spring systems, to ensure the tightness requirements for the seat of the filter element according to DIN 25 496, table 3, under conditions of a retreating sealing caused by e. g. aging. Quick release of the clamping devices by means of single acting pneumatic cylinders for filter element exchange. The cylinders to be supplied with compressed air (6 bar oil-free and water-less) via a three-way valve positioned at the front side of the filter housing. So for the inflating and also for the deflating of the cylinders the air is always released into the filter housing safely.
- The clamping devices of the HEPA filter elements are operated from outside and designed to ensure the tightness requirements for the seat of the filter element according to DIN 25 496, table 3, under conditions of maximum loading of the filter elements and a retreating sealing.
- Test grooves according to DIN 1946-4 and DIN 25 414 resp. for the HEPA filter elements made of stainless steel. In order to proof the leak free seat of the filter elements the test groove can be connected to a leak test device (see accessories) via fast acting coupling, positioned at the front side on the filter housing.
- Each filter element is sealed to the housing on both sides using the 3-seal concept (Triple S) so that the barrier from the inside to the outside of the filter housing remains intact even if the maintenance cover is removed.
- The fixture for the fine dust and the HEPA filter elements in horizontal or vertical design.
- Each filter line equipped with a separate insertion port with a special collar.
- The changing of the filter elements using the bag in bag out method without contaminating the environment shall be possible.
- The special collar has two circumferential sealing grooves according to DIN 25 466, supp. 1, to take the hollow rubber band for the plastic bag fixation. Undercut groove with perfectly matched hollow rubber band to ensure a gastight seat of the plastic bag.
- Maintenance cover made from 1.4301 to protect the special collar, the maintenance bag and other built in parts.
- Bolting of the maintenance cover to the filter housing by four hand screws. Each maintenance cover has a central grip for easy handling.
- Selective filter loading monitoring of each filter stage consisting of a Magnehelic® differential pressure gauge, (optional with signal transmitter) instrument holders, connections and connecting lines
  - from stainless steel or
  - nickel coated brass.The inlet and outlet side of the pressure monitoring line are completed with a ball cock
  - from stainless steel or
  - nickel coated brassand an U15-filter each. Additionally the measuring line is equipped with a disinfection connection.
- The filter housing is equipped with one raw air and one clean air spigot made from 1.4301 in leak tight design. The spigots are designed as even closure, bolted to the filter housing by a circumferential rim and silicon gaskets. Welded to the spigots is a circular adapter for a gastight damper. A perforated plate is arranged in the air inlet to ensure a uniform loading of the filter stages. Gastight dampers on raw air side and clean air side are protected against cascading parts by covers.
- Each connection is secured twice against spreading of contamination to the outside. For that purpose each particle measuring line is equipped with manual operated ball cocks and fast acting couplings suited for disinfection and decontamination. Both can be made
  - from stainless steel or
  - nickel coated brass.
- The housing is equipped with a bleed filter device consisting of a gas tight ball cock and an ULPA-Filter U 15.

- The air flow direction on the raw air and on the clean air side is horizontal or vertical.
- The filter housing is equipped with disinfection nozzles. Additionally the ball cock on the disinfection inlet nozzle is equipped with a limit switch which, due to safety reasons, only unlocks the disinfection device connected to it once the ball cock is in "open" position. Also all other connections are provided with a gassing option sealed with ball cocks and locking cups. Gassing is possible once the filter elements are released (not clamped) so that the filter elements and the sealing are flushed during disinfection. The disinfection concept is configured for formalin disinfection. Alternatively hydrogen peroxide or  $\text{CH}_3\text{COOH}$  may be used.
- The filter housing is equipped with a fully automatic scanner behind each HEPA filter stage. The special engineered and patented scanner bar allows the filter elements to be efficiency checked in operation. All measuring lines are optional from stainless steel or nickel coated brass. They are led through gas tight housing penetrations and can be connected to the mobile filter efficiency test rack. The scanner bar is actuated by an electrical motor installed outside the housing and protected by a maintenance cover.
- The filter housing is placed on the floor with its integrated support made from 1.4301. So an exchange of filters in optimal working height is provided. The support shall be bolted to the floor.
- To perform the filter inspection during operation two mobile test racks are connected to the filter. In the first rack all devices for measuring particle feeding (compressor, aerosol generator and mixing box) are installed. This is connected to the particle feeding probe in the filter housing. The second rack contains the diluting stages, the optical particle counters (OPC) for the raw air and for the clean air side as well as the computer for the automatic control of the scanning process and the evaluation of the results.

The limit switches are installed outside the filter housing and accessible for service without opening the filter housing. After particle counting the used air is led back to the air inlet side of the filter stage inside the filter housing. The aerosol feeding probe in front of the HEPA filter stage is designed as manifold tube with holes. Additionally in front and behind the HEPA filter stage extracting probes are installed. All probes are lead to the outside of the filter housing with a ball cock and a fast acting coupling, optional

- from stainless steel or
- nickel coated brass.



## Accessories

### Leak tightness test device

to check the leak tightness of the HEPA filter sealing and the gastight damper seat.

In order to guarantee the performance of components and systems in laboratories it is very important to check and proof the integrity of seals for filters and dampers. Krantz developed a special portable leak test device.

This leak test device allows to check and measure the acceptable leak air flow acc. to DIN 25 496 or DIN 25 414 for

- seat of filter elements
- damper blades
- filter housings

in a range of 0.01 to 1.5l/min. up to a test pressure of 3,500Pa. The measuring devices of the leak test device have been calibrated before assembly.

### Heat sealing device

for changing the filter elements using the bag-in bag-out method.

Due to the exceptionally high safety requirements in nuclear facilities, laboratories etc., Krantz has developed a unique "safe change" procedure utilizing the heat sealing device.

The Krantz heat sealing device provides ease of handling and guarantees optimum safety. The maintenance bag is gathered clamped tightly and heat sealed so that the contents of the maintenance bag and the inside of the filter housing be sealed and separated in one simple process. The Krantz heat sealing device consists of the heated element, transformer and clamping device.

### Disinfection System

To disinfect the filter housing when needed or before a change of filter elements, Krantz has developed a special disinfection system which works with formalin. The disinfection system is connected to the filter housing by nozzles equipped with ball cocks. The ball cock on the inlet nozzle is equipped with a limit switch which, due to safety reasons, only unlocks the disinfection device connected to it once the ball cock is in "open" position.



Disinfection system for disinfection by formalin



## Contacts

Caverion Deutschland GmbH  
Riesstraße 25  
80992 München, Germany  
Phone: +49 89 374288-500  
Fax: +49 89 374288-520

Krantz Filter Systems and Dampers  
Uersfeld 24  
52072 Aachen, Germany  
Phone: +49 241 434-1  
Fax: +49 241 434-500

Production workshop  
Mallersdorf  
Schillerstraße 16  
84066 Mallersdorf-Pfaffenberg, Germany

Claus Schweinheim  
Division Manager  
Krantz Filter Systems and Dampers  
Phone: +49 241 434-501  
Fax: +49 241 434-500  
Mobile: +49 173 3888718  
email: claus.schweinheim@krantz.de

Reinhold Goettgens  
Sales Manager  
Phone: +49 241 434-269  
Fax: +49 241 434-500  
Mobile: +49 174 1658185  
email: reinhold.goettgens@krantz.de