

Please note,  
type code is new,  
see last page.

## Technical Selection



- Variable twist outlet with**
- guide ring DD-VL....
  - jet straightener DD-VG....

DS 4033 E 03.2007

## Preliminary remarks

The variable twist outlet with guide ring generates turbulent mixing air flow and is used for air supply where there is no significant pollutant load. It is very well suited for high rooms or halls where it is placed above the occupied zone.

The variable twist outlet with guide ring designed for duct connection has excellent acoustic properties. It can therefore be used in rooms calling for low sound pressure levels such as broadcasting studios, theatres and concert halls. If fitted with a jet straightener, this outlet can achieve large vertical penetration depths in the heating mode, at high temperature differences between supply air and indoor air. For this reason it is also eminently suitable for use in high halls such as exhibition halls and painting hangars.

## Construction design and function

The air outlet mainly consists of the outer cylinder **1**, the core chamber **2**, the rounded exit **3**, and the individual twist vanes **4**. The twist vanes are fixed to the outer cylinder and the core chamber. The rounded exit is fitted with a coaxially mobile guide ring **5** whose height can be adjusted by a lift of 80 to 120 mm, depending on the outlet size. So the discharge direction of the air jets can be adjusted from horizontal (when cooling) to vertically downwards (when heating), manually or with a servomotor **6**.

The variable twist outlet with guide ring is used for discharge heights of 3 m to 10 m. A jet straightener **7** is inserted in the guide ring for discharge heights of up to 25 m.

The air outlet can be connected to the duct system either directly using a circular duct, or via a connection box. It may also be connected to the bottom of a rectangular duct, using a spigot to be provided by the client (for details see page 3).

Nominal diameter		DN 315	DN 400	DN 630
Volume flow rate	l/s	170 – 550	280 – 970	830 – 2500
	m <sup>3</sup> /h	600 – 2000	1000 – 3500	3000 – 9000
Discharge height with				
– guide ring	m	3 – 9	4 – 10	5 – 10
– jet straightener	m	5 – 15	6 – 20	7 – 25
Max. temperature difference $\Delta\vartheta$ between supply air and indoor air		– 10 K when cooling + 15 K when heating, with guide ring + 20 K when heating, with jet straightener		



Variable twist outlet  
Above: with guide ring; Below: with jet straightener

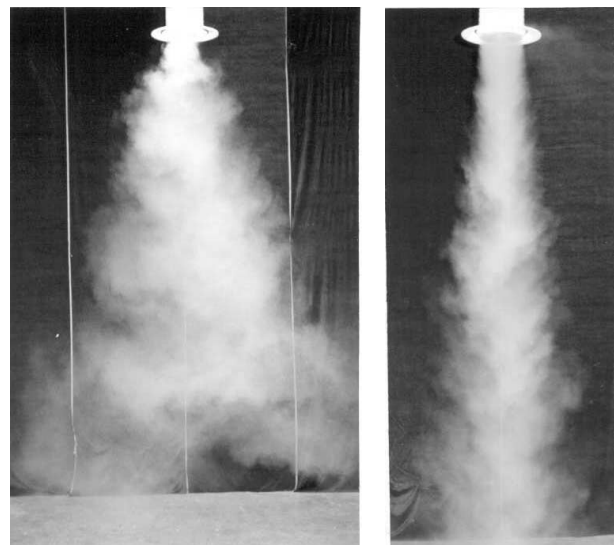

Jet dispersion made visible with smoke tracer  
Above: cooling mode - The cool supply air is discharged horizontally and flows downwards slowly and evenly  
Below: heating mode - The warm vertical supply air jets penetrate deep into the occupied zone,  
left: with guide ring, right: with jet straightener

Connection to circular duct

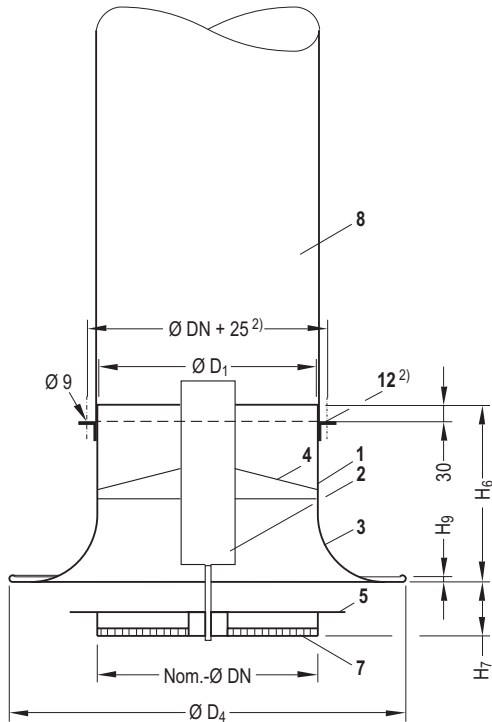

Connection to rectangular duct with spigot

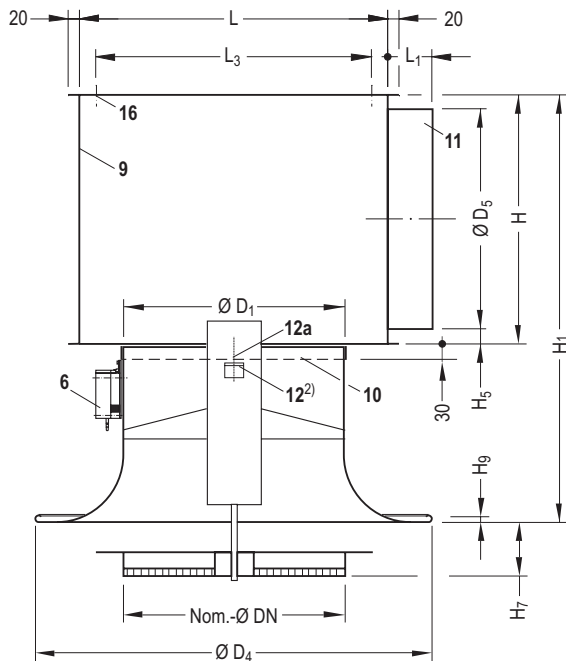
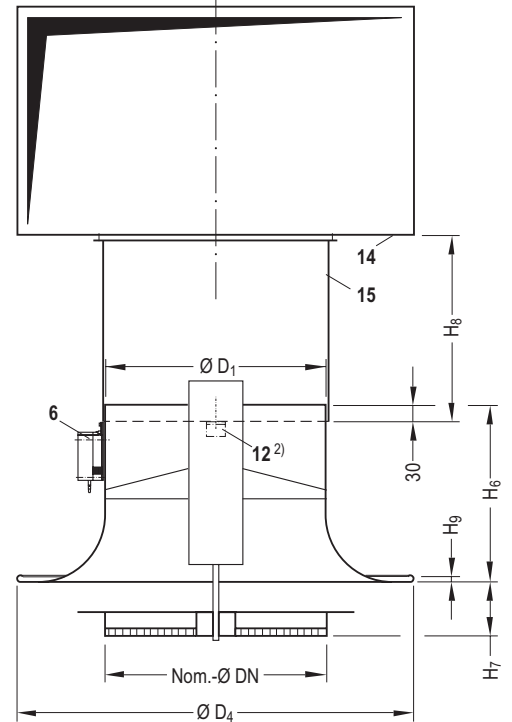

Connection to connection box

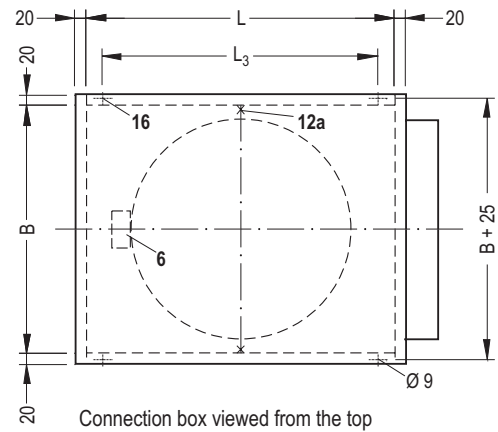

**Key:**

- |                    |  |
|--------------------|--|
| 1 Outer cylinder   | 9 Connection box                         |
| 2 Core chamber     | 10 Sleeve at connection box              |
| 3 Exit             | 11 Connection spigot                     |
| 4 Twist vane       | 12 L-fastener <sup>2)</sup> (on 2 sides) |
| 5 Guide ring       | 12a Screw connection to box bottom       |
| 6 Servomotor       | 14 Rectangular duct                      |
| 7 Jet straightener | 15 Spigot for duct connection            |
| 8 Circular duct    | 16 Hole for suspension                   |

Size DN	Dimensions in mm											Weight in kg <sup>1)</sup>					
	L	L <sub>1</sub>	L <sub>3</sub>	B	H	H <sub>1</sub>	H <sub>5</sub>	H <sub>6</sub>	H <sub>7 max</sub>	H <sub>8 min</sub>	H <sub>9</sub>	Ø D <sub>1</sub>	Ø D <sub>2</sub> <sup>3)</sup>	Ø D <sub>4</sub>	Ø D <sub>5</sub>	Air outlet	With connection box
315	475	60	415	365	365	690	25	320	90	500	12	314	500	565	314	6	16,5
400	560	80	500	450	450	775	25	320	106	600	12	399	650	720	399	8	23
630	790	80	730	680	680	1185	25	500	110	950	12	628	1000	1080	628	17	42

1) Without servomotor; weight of servomotor 0.5-0.8 kg

3) Ceiling cutout

2) In case of connection to a box and mounting flush with the ceiling, the L-fastener is positioned inside (Ø DN 30mm)

## Comfort criteria

The layout of the radial outlet will be based on compliance with the required maximum permissible indoor air velocities. First you have to determine the maximum specific volume flow rate  $\dot{V}_{Sp\ max}$  depending on the indoor air velocity  $u$  and the discharge height  $H$  as per diagram 1.

The minimum outlet centre spacing  $t_{min}$  will then be determined according to diagram 2 on the basis of the maximum specific volume flow rate and the outlet volume flow rate.

## Maximum specific volume flow rate

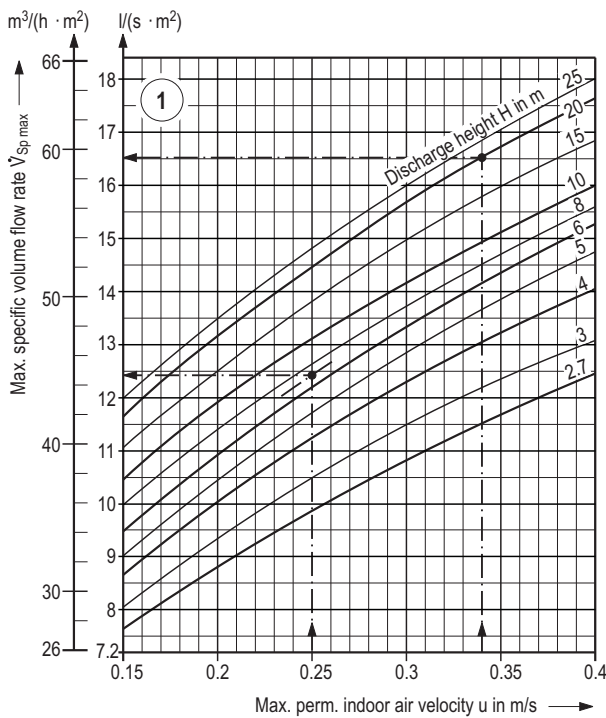

### Key for all graphs:

- $\dot{V}_A\ max$  = Max. volume flow rate per twist outlet when cooling
- $\dot{V}_A\ min$  = Min. volume flow rate per twist outlet when cooling
- $\dot{V}_A\ min\ H$  = Min. volume flow rate per twist outlet when heating at  $\Delta\vartheta = \dots K$
- $\dot{V}_A$  = Selected volume flow rate per air outlet
- $\dot{V}_{Sp\ max}$  = Max. specific volume flow rate per  $m^2$  of floor area
- $u$  = Max. permissible indoor air velocity
- $t_{min}$  = Minimum air outlet centre spacing
- RV = Duct connection, vertical discharge
- RH = Duct connection, horizontal discharge
- KV = Box connection, vertical discharge
- KH = Box connection, horizontal discharge

## Minimum air outlet centre spacing

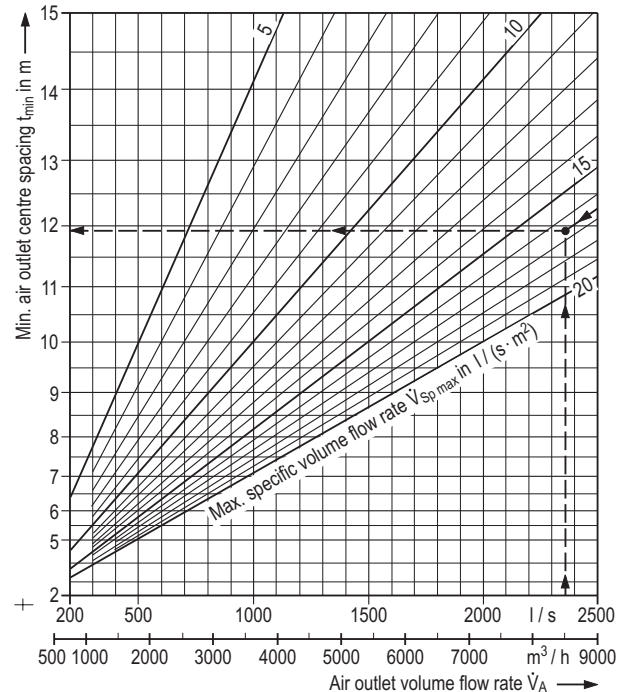
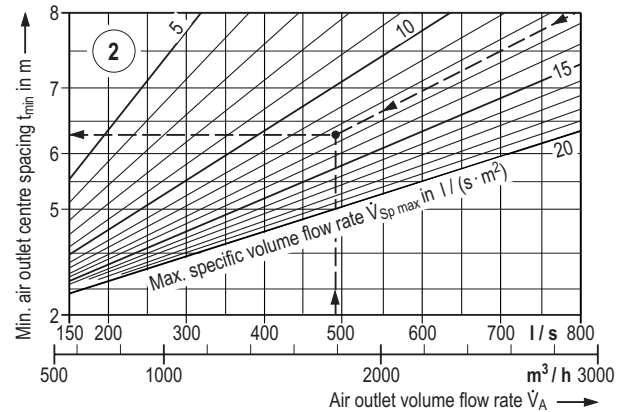

Layout example		Assembly shop for electrical equipment	Aircraft painting hangar
Outlet type, size		Guide ring, DN 315	Jet straightener, DN 630
Connection to		Circular duct	Circular duct
1 Supply air volume flow rate $\dot{V}$	l/s	8 890	75 000
2 Discharge height $H$	m	7	20
3 Floor area $A$	$m^2$	1 450	14 000
4 Max. perm. sound power level $L_{WA}$	dB(A) ref. $10^{-12}W$	65	75
5 Max. temperature difference Supply air-Indoor air:			
$\Delta\vartheta_{when\ cooling}$	K	-6	-5
$\Delta\vartheta_{when\ heating}$	K	7.5	5
6 Max. permissible indoor air velocity $u$	m/s	0.25	0.34
7 Max. specific volume flow rate $\dot{V}_{Sp\ max}$	$l/(s \cdot m^2)$	12.36	16.53

From nomogram:			
8 $\dot{V}_A\ max$	l/s	528	2 500
9 $\dot{V}_A\ min\ H$	l/s	444	2 111
		[at $\Delta\vartheta=7.5K$ ]	[at $\Delta\vartheta = 5K$ ]
10 $\dot{V}_A\ selected$	l/s	492	2 361
11 $Z$ [from 1 : 10]	units	18	32
12 $L_{WA}\ max$	dB(A) ref. $10^{-12}W$	$\approx 54$	$\approx 71$
13 $\Delta p_{t\ max}$	Pa	$\approx 85$	132
14 $t_{min}$	m	$\approx 6.3$	$\approx 12$

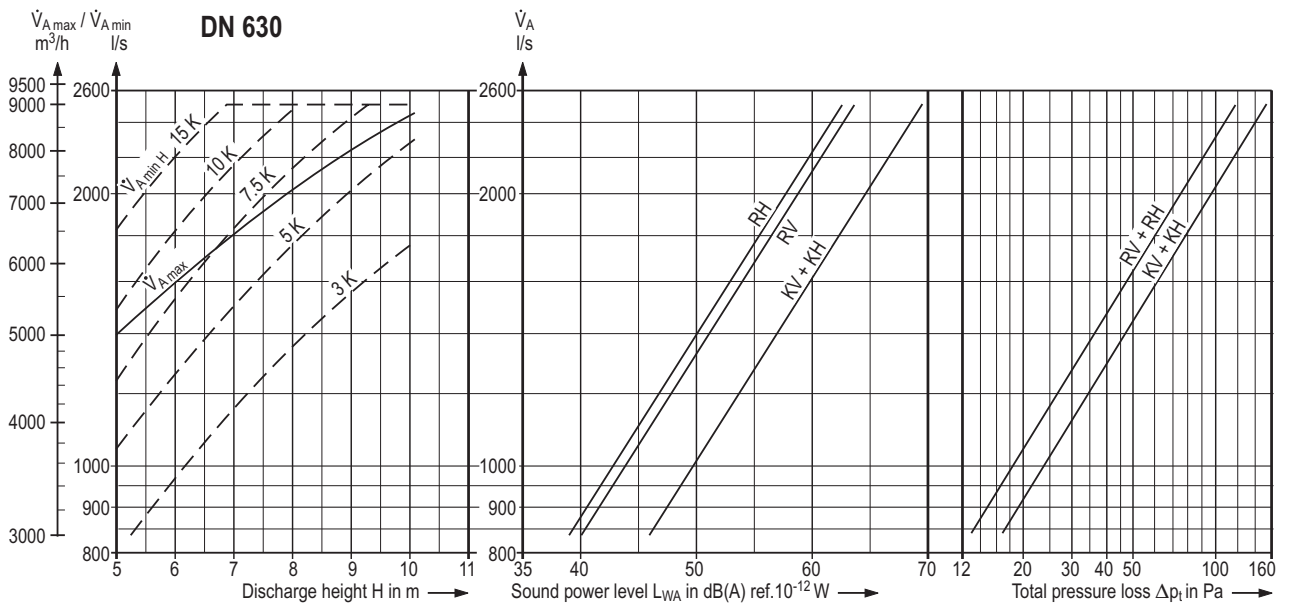
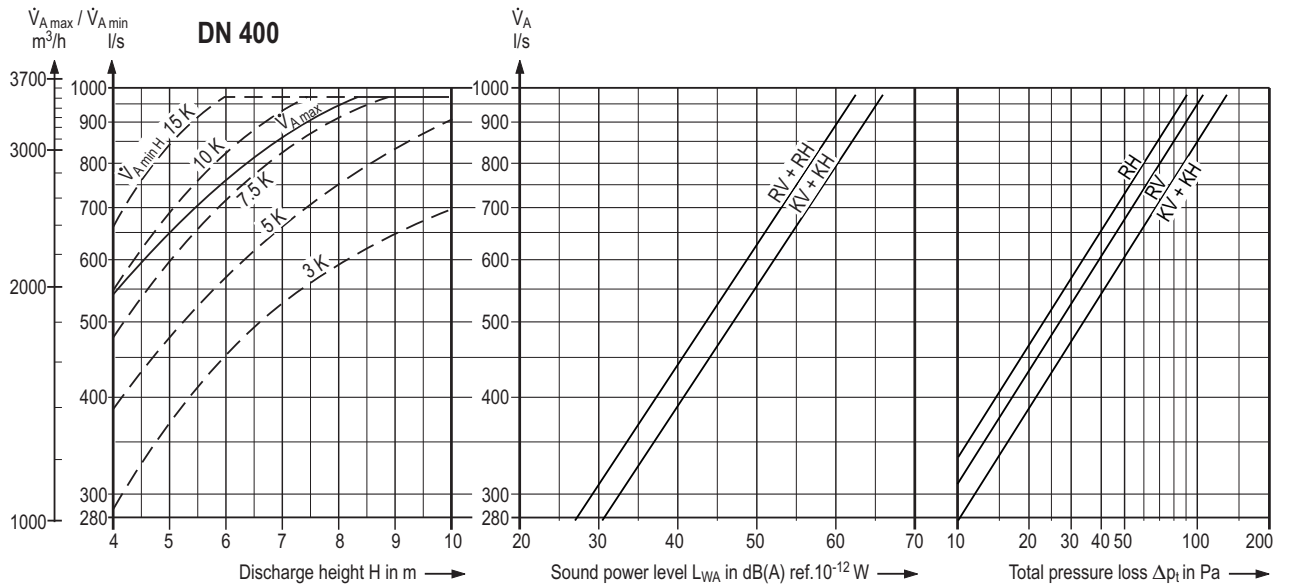
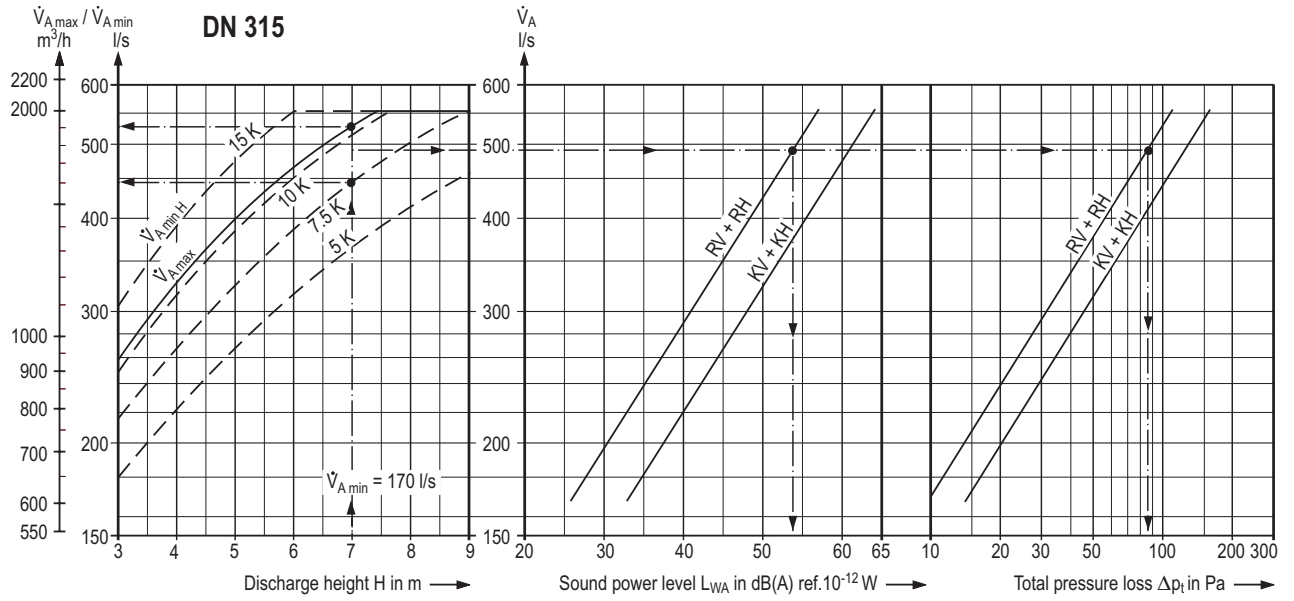

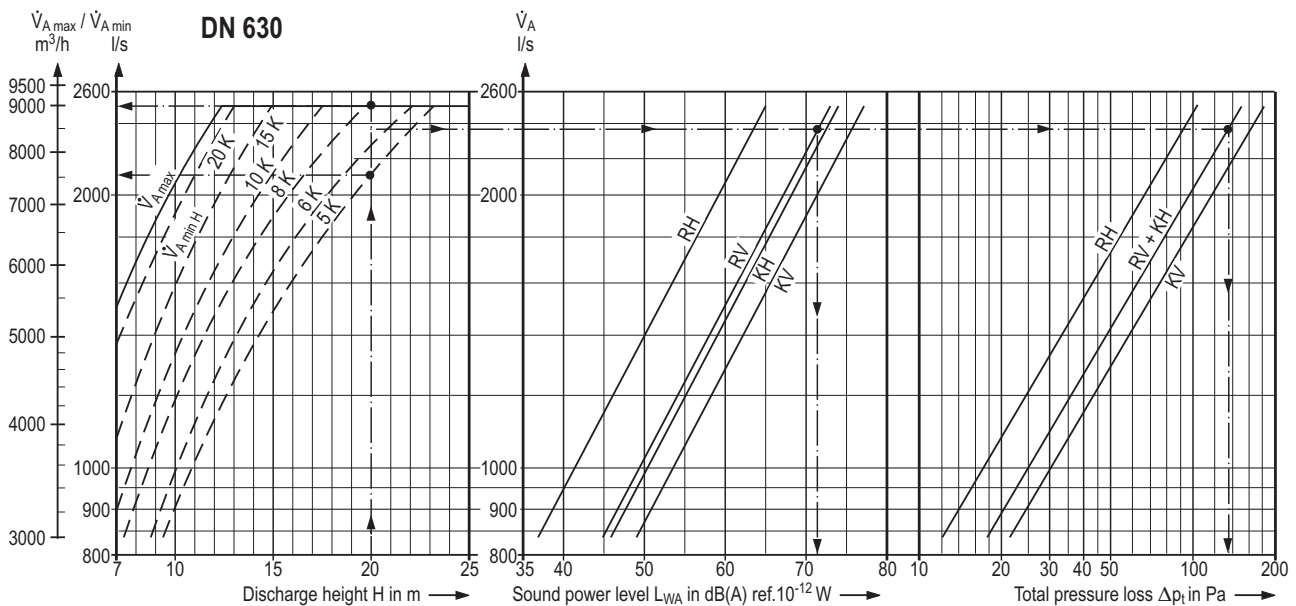
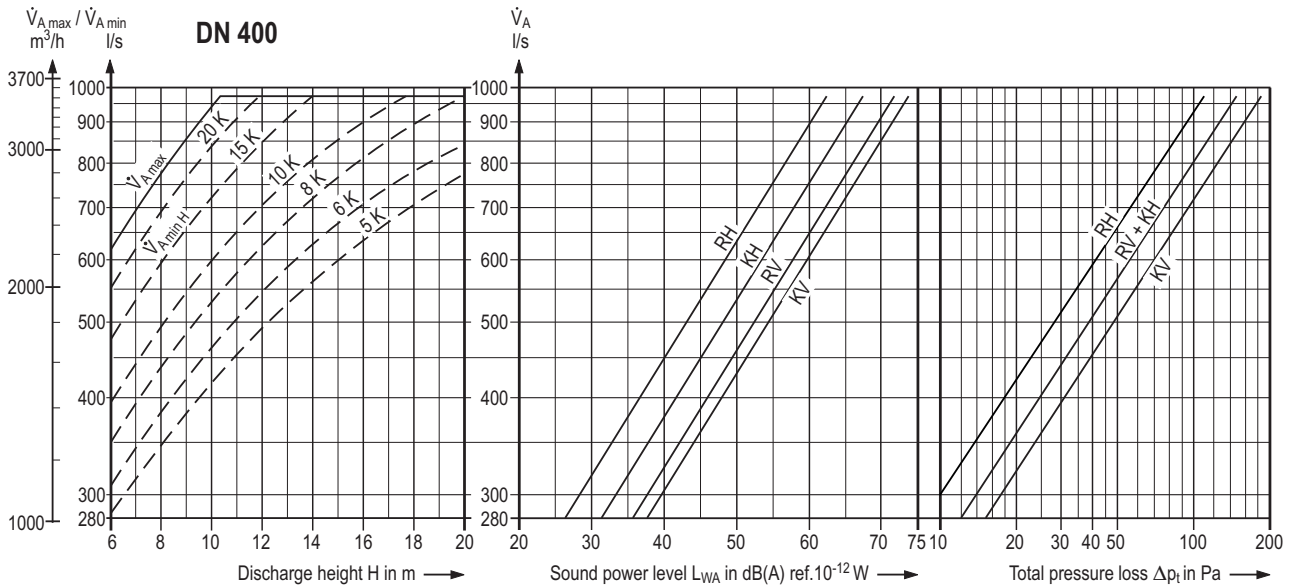
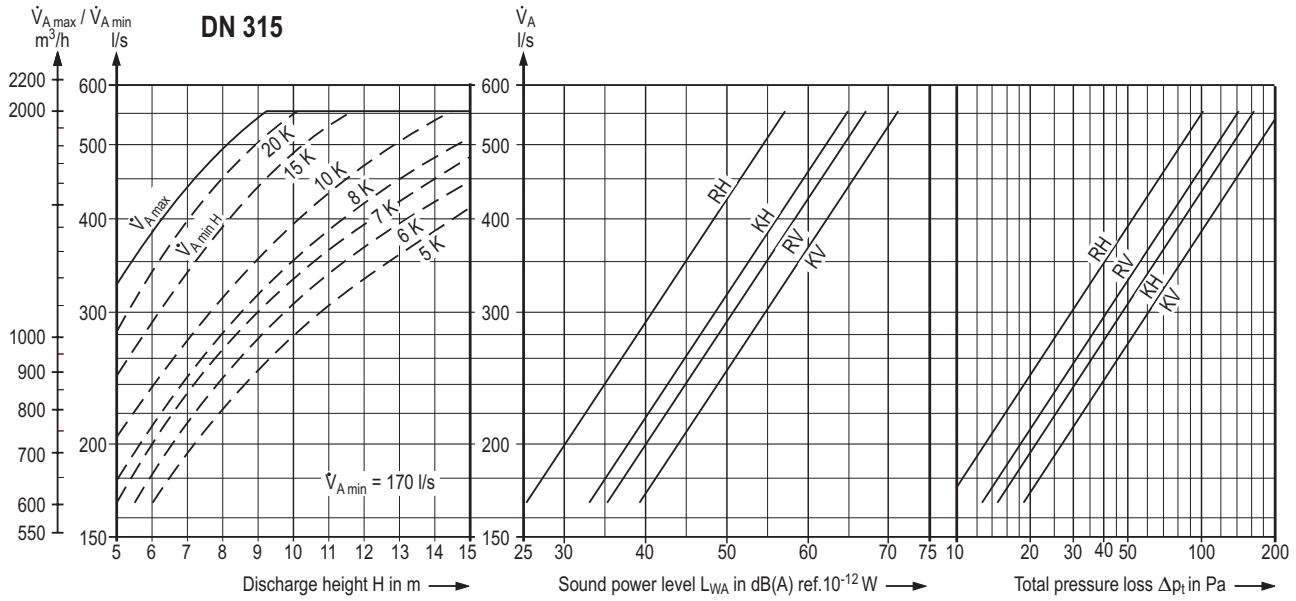

Air outlet volume flow rate $\dot{V}_A$		Duct connection	Total pressure loss $\Delta p_t$	Sound power level $L_W$ in dB ref. $10^{-12}W$								Connection box	Total pressure loss $\Delta p_t$	Sound power level $L_W$ in dB ref. $10^{-12}W$							
				LWA	Octave band centre frequency in Hz									LWA	Octave band centre frequency in Hz						
l/s	m <sup>3</sup> /h		Pa	dB(A)	125	250	500	1 K	2 K	4 K	8 K		Pa	dB(A)	125	250	500	1 K	2 K	4 K	8 K
<b>Variable twist outlet with guide ring</b>																					
<b>DN 315</b>																					
280	1 000	RH	27	39	44	37	35	33	32	16	<15	KH	40	46	49	40	43	42	37	28	18
		RV	27	39	40	43	36	32	31	21	<15	KV	40	46	48	42	43	42	37	29	19
415	1 500	RH	60	49	54	49	46	42	41	35	23	KH	90	57	60	53	54	52	48	43	31
		RV	60	49	47	51	48	42	40	36	30	KV	90	57	56	54	56	50	47	43	34
555	2 000	RH	115	57	62	57	54	50	49	43	30	KH	160	64	67	60	61	60	55	50	38
		RV	115	57	55	59	56	50	48	44	38	KV	160	64	63	61	63	58	54	50	41
<b>DN 400</b>																					
415	1 500	RH	7	38	37	32	38	36	22	<10	<10	KH	23	42	41	41	40	38	30	14	<10
		RV	19	38	44	37	40	35	22	<10	<10	KV	25	42	42	42	42	36	27	16	<10
555	2 000	RH	30	46	47	41	46	44	34	20	<10	KH	41	50	48	48	49	46	39	26	<15
		RV	34	46	50	46	47	43	34	23	<10	KV	44	50	49	50	50	45	38	28	<15
835	3 000	RH	67	58	61	54	58	55	50	40	26	KH	92	62	60	59	62	58	53	43	31
		RV	77	58	58	57	58	53	51	43	31	KV	98	62	59	62	62	57	52	45	33
<b>DN 630</b>																					
1400	5 000	RH	36	50	53	49	46	46	42	32	24	KH	47	57	57	52	56	53	46	35	25
		RV	36	51	53	50	47	45	46	37	28	KV	47	57	56	58	56	50	47	40	32
1800	6 500	RH	61	56	59	55	51	50	49	42	32	KH	80	63	65	59	61	58	54	45	36
		RV	61	57	57	56	52	51	51	46	35	KV	80	63	63	65	61	58	54	48	39
2220	8 000	RH	93	60	64	59	55	54	54	50	40	KH	121	67	72	64	65	62	60	52	44
		RV	93	61	60	61	56	55	55	53	43	KV	121	67	68	69	66	61	58	53	44

<b>Variable twist outlet with jet straightener</b>																					
<b>DN 315</b>																					
280	1 000	RH	25	39	42	38	36	33	32	21	<15	KH	40	47	50	41	44	43	39	29	16
		RV	35	49	43	45	45	44	42	42	42	32	KV	50	53	49	46	49	49	45	43
415	1 500	RH	56	50	55	50	47	43	43	36	28	KH	90	57	61	53	55	53	49	44	34
		RV	78	59	49	52	53	53	51	51	47	KV	118	63	57	56	59	58	55	54	51
555	2 000	RH	100	57	62	57	54	50	50	43	35	KH	160	65	68	60	62	61	56	51	41
		RV	139	67	57	60	61	61	59	59	55	KV	208	71	65	64	67	66	63	62	59
<b>DN 400</b>																					
415	1 500	RH	20	38	37	33	37	34	25	<10	<10	KH	26	43	44	39	42	40	33	22	<15
		RV	28	47	44	45	45	42	37	30	14	KV	34	49	47	45	48	43	41	35	25
555	2 000	RH	35	46	47	43	45	42	36	23	11	KH	47	52	52	47	51	48	41	30	18
		RV	50	55	50	53	53	51	47	43	30	KV	60	57	55	52	54	52	51	48	40
835	3 000	RH	79	58	60	56	57	53	51	42	32	KH	104	63	64	57	63	58	54	47	39
		RV	112	67	60	64	64	63	62	62	51	KV	135	69	65	63	66	63	62	59	54
<b>DN 630</b>																					
1400	5 000	RH	32	50	53	46	46	45	43	32	24	KH	47	59	58	59	58	54	47	39	31
		RV	47	58	51	50	54	54	49	48	39	KV	57	62	58	59	60	57	52	51	47
1800	6 500	RH	54	56	59	52	54	50	49	42	33	KH	80	66	66	67	64	60	56	48	40
		RV	80	65	59	58	62	59	57	56	47	KV	97	69	66	67	66	63	60	59	55
2220	8 000	RH	82	61	64	57	60	54	54	50	40	KH	121	71	72	73	69	65	63	55	47
		RV	120	70	65	64	68	63	63	62	53	KV	147	74	72	73	71	68	66	65	61

## Features

- Turbulent mixing air flow
- Volume flow rate range of 170 to 2500 l/s (600 to 9000 m<sup>3</sup>/h)
- Jet penetration depth adaptable to room height and thermal load
- Even temperature and humidity distribution throughout the room
- Discharge direction adjustable from horizontal to vertically downwards
- Adjustment manually or with servomotor
- Discharge height for outlet with guide ring: 3 to 10 m, for outlet with jet straightener: best from 5 to 25 m
- Maximum temperature difference supply air–indoor air:  
–10 K when cooling  
+15 K when heating, with guide ring  
+20 K when heating, with jet straightener
- Sizes: DN 315, DN 400 and DN 630
- Low weight since entirely made from aluminium (powder-coated)
- Different connection types
- Can be fitted with ST-E temperature difference control device from KRANTZ KOMPONENTEN for optimum jet penetration depth
- Accelerated heating-up operation
- For commercial and industrial applications

## Type code

DD - V \_ - DN \_ - \_ -

Ceiling twist outlet  
Adjustable Function / Kind  
Size  
Connection type  
Adjustment

Please note,  
type code is new,  
see last page.

**Size:**  
DN 315, DN 400, DN 630

## Function / Kind:

- L = Outlet with guide ring  
G = Outlet with jet straightener  
(Guide ring with air flow straightener)

## Connection type

- R = Duct connection or spigot at duct  
K = Connection box

## Adjustment

- M = Manual  
E = With electric servomotor

## Tender text

..... units

Variable twist outlet,  
for air supply from large discharge heights with high-induction radial air jets, discharge direction adjustable from horizontal to vertically downwards, consisting of:

outer cylinder with rounded exit and core chamber as well as twist vanes fixed between outer cylinder and core chamber,

with

- steplessly adjustable guide ring for discharge heights of 3 to 10 m,
- steplessly adjustable jet straightener, best used for discharge heights of 5 to 25 m,

- Adjustment by hand.
- Adjustment by electric servomotor.

## Connection

- direct to circular duct.
- via connection box with lateral spigot, made from galvanized sheet metal.

## Technical data

Volume flow rate: ..... l/s (m<sup>3</sup>/h)

Size: DN .....

Perm. sound power level: ..... dB(A) ref.10<sup>-12</sup>W

Material: Aluminium powder-coated to RAL .....

Make: KRANTZ KOMPONENTEN

Type: DD - V \_ - DN \_ - \_ -

– Subject to technical alteration –



# Variable twist outlet with guide ring or jet straightener



Variable twist outlet with guide ring



Variable twist outlet jet straightener

**Function / Kind:**

- VL = variable with guide ring
- VG = variable with jet straightener

**Size:**

DN 315, DN 400, DN 630

**Connection type:**

- R = Duct connection with rivet or screw connection <sup>1)</sup>
- K = Connection box <sup>1)</sup>

**Adjustment:**

	DN 315 + DN 400	DN 630
MA = manual	•	•
E7 = „Belimo servomotor, 0-10 V modulation“, rotation drive type NM24A-SR	•	
E8 = „Belimo servomotor, 3-point drive, 24 V“, rotation drive type NM24A	•	
E9 = „Belimo servomotor, 3-point drive, 230 V“, rotation drive type NM230A	•	
E10 = „Belimo servomotor, 0-10 V modulation“, rotation drive type SM24A-SR		•
E11 = „Belimo servomotor, 3-point type, 24 V“, rotation drive type SM24A		•
E12 = „Belimo servomotor, 3-point type, 230 V“, rotation drive type SM230A		•
E13 = „Siemens servomotor, 0-10 V modulation“, rotation drive type GLB161.1E	•	
E14 = „Siemens servomotor, 3-point type, 24 V“, rotation drive type GLB131.1E	•	
E15 = „Siemens servomotor, 3-point type, 230 V“, rotation drive type GLB331.1E	•	
E19 = „Siemens servomotor, 0-10 V modulation“, rotation drive type GEB161.1E		•
E20 = „Siemens servomotor, 3-point type, 24 V“, rotation drive type GEB131.1E		•
E21 = „Siemens servomotor, 3-point type, 230 V“, rotation drive type GEB331.1E		•

**Surface finish:**

. . . . = Face painted to RAL .....

**Type code**

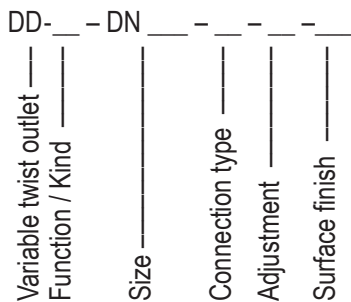

Subject to technical alteration.

<sup>1)</sup> L-fastener

- inside in case of box connection,
- outside in case of connection to circular duct