

## Radial outlet RA-N2....

# Radial outlet RA-N2

## Preliminary remark

KRANTZ KOMponenten radial outlets RA-N2 have 24 fixed radial vanes and are available with circular or square face. They generate high-quality diffuse air flow according to the principle of turbulent mixing air flow. They can be installed flush with closed false ceilings or square tile ceilings, above open grid or expanded metal ceilings, or freely suspended from the ceiling.

RA-N2 radial outlets achieve a high level of thermal comfort and can be used for volume flow rates up to 394 l/s [1 420 m<sup>3</sup>/h] at temperature differences up to -12 K when cooling and +10 K when heating ( $\leq 3$  m) or +5 K ( $> 3$  m).

## Mode of operation

The radial outlet **1** discharges the supply air in the horizontal direction, a feature which is enhanced by the slanting exit. The high-turbulence supply air jets induce a large proportion of indoor air, which leads to fast temperature equalization of supply air and indoor air as well as to a rapid decrease in jet velocity.

Thanks to its stable supply air distribution pattern at low sound power levels this outlet can be used safely for a wide range of air volume flow rates.

## Construction design

The RA-N2 outlet with circular face is available in 7 sizes (DN 250 to DN 500) and is fitted on the outside with a flush contact edge for ceiling attachment (see detail Y on page 4).

The RA-N2 outlet with square face is available in 6 sizes (DN 250 to DN 450). The square face with all-side 90° turn-up (Q1 and Q2) is designed for installation in square tile ceilings (see detail Z on page 4).

Both outlet models are made of powder coated sheet metal and are fastened to the reducer or connection box with a screw **5** whose head is concealed by a cap **5a** having the same powder coating as the outlet.

## Installation options

The following connection types are available for connection to the duct system:



Connection type A, with reducer for duct connection



Connection type D, with connection box for closed false ceilings

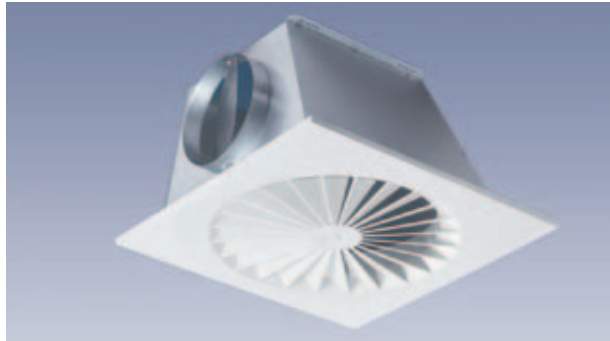

Connection type F, with connection box for square tile ceilings

## Application

Size DN	Volume flow rate				Max. temperature difference supply air–indoor air $\Delta\vartheta$
	$\dot{V}_{A \text{ min}}$		$\dot{V}_{A \text{ max}}$		
	l/s	m <sup>3</sup> /h	l/s	m <sup>3</sup> /h	
250	28	100	97	350	-12 K when cooling +10 K when heating ( $\leq 3$ m) + 5 K when heating ( $> 3$ m)
280	36	130	125	450	
315	44	160	153	550	
355	56	200	183	660	
400	72	260	231	830	
450	94	340	306	1 100	
500	114	410	394	1 420	

# Radial outlet RA-N2

## Connection type A

The 'A' reducer is fitted with 2 or 3 suspension brackets for fixing to the ceiling as well as with a threaded device for the central fastening of the outlet. The reducer can be connected to spiral seam or flexible ducts. For installation in a closed false ceiling upon completion of said ceiling, the radial outlet with flush contact edge shall be inserted into the reducer through the ceiling cutout and screwed up.

## Connection type D

The RA-N2 outlet is connected to the duct system via the lateral spigot of a flat connection box. This connection type is well suited for outlets to be installed above open or closed false ceilings. The connection box is fitted with 4 suspension brackets for fixing to the ceiling and a threaded device for the central fastening of the outlet.

The optional volume flow damper positioned in the lateral connection spigot can be adjusted through the openings of the radial outlet.

## Connection type F

This connection type is particularly suitable for square tile ceilings. The square radial outlet with connection box is inserted into the ceiling from the top, in place of a ceiling tile. The connection box is fixed to the load-bearing ceiling and the outlet is screwed to the connection box via the central fastener.

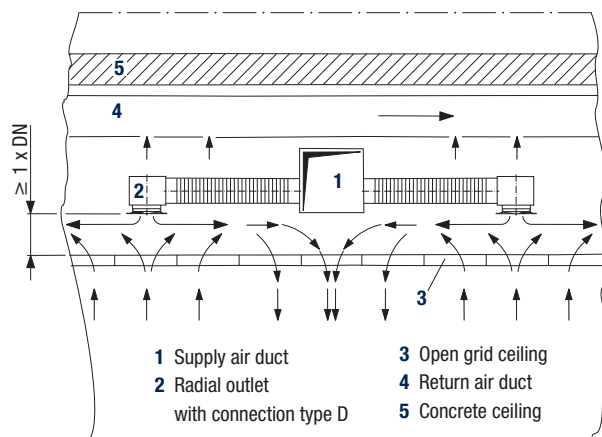

Radial outlets installed above an open grid ceiling.

The return air is removed evenly through the whole ceiling and extracted by the return air duct positioned immediately above the outlets.

## Design specifications

Basically, the radial outlet RA-N2 can also be installed freely suspended from the ceiling regardless of its connection type.

Radial outlets discharging supply air may be positioned close to return air openings or inlets.

Disruptions in jet dispersion or risks of short-circuiting are ruled out if the height difference between the planes of return air intake and supply air discharge is minimum 250 mm. If the radial outlet and the return air opening or inlet are in the same plane, the horizontal centre spacing should be at least five times the nominal diameter ( $5 \times DN$ ) of the outlet.

## Sketches of installation options

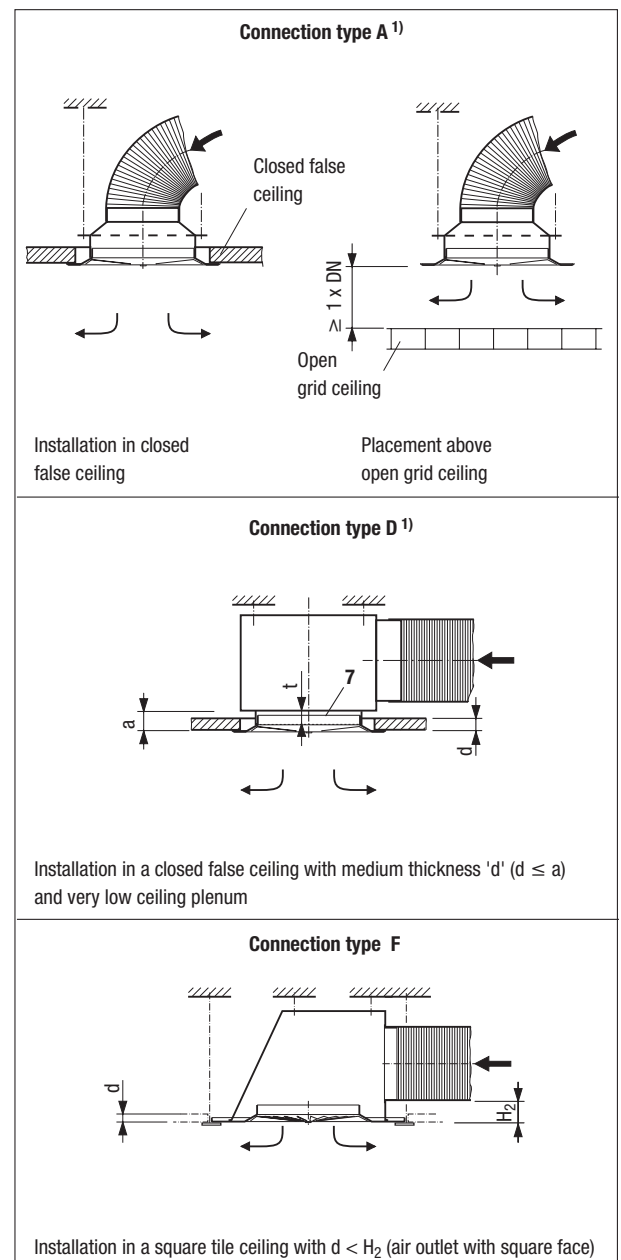

<sup>1)</sup> For circular or square face

# Radial outlet RA-N2

## Dimensions of outlet element and connection type A

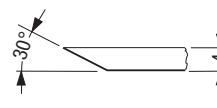
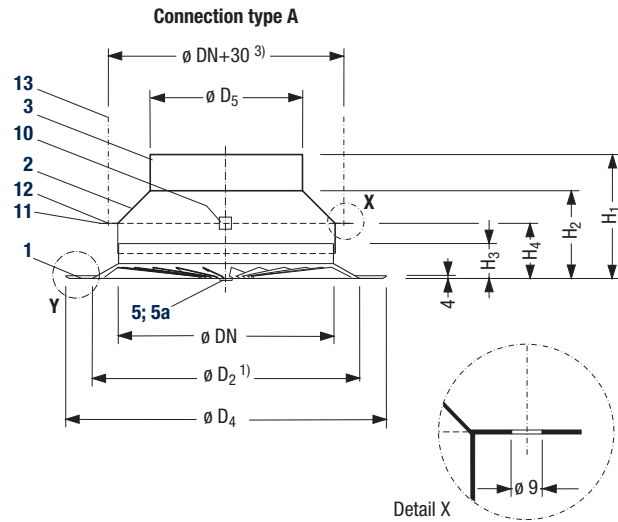
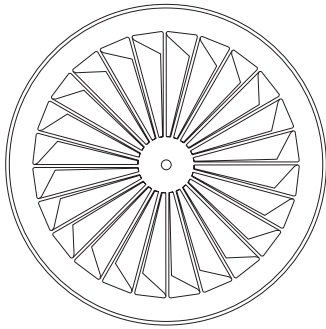
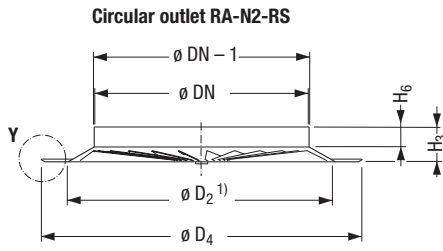

**Detail Y**  
RS - circular face  
Flush contact edge  
for ceiling attachment

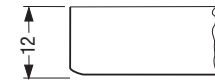

**Detail Z**  
Q1 and Q2 - square face  
90° turn-up for installation  
in square tile ceilings

**Square outlet RA-N2-Q1 or RA-N2-Q2**

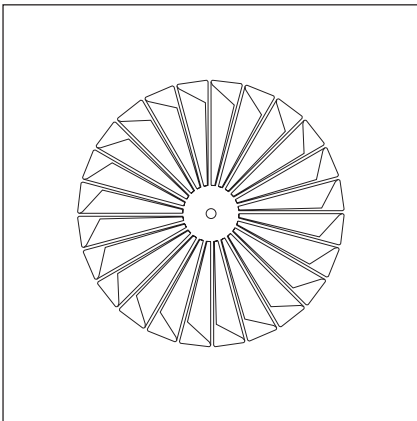
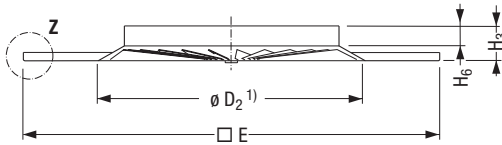

Key for all pages	Material
1 Radial outlet	galvanized sheet metal, powder coated
2 Reducer	aluminium
3 Duct connection	—
4 Connection box	galvanized sheet metal
5 Fastening screw	galvanized sheet metal
5a Screw cap	brass, powder coated
6 Acoustic lining (optional)	mineral wool
7 Sleeve at box 'D'	galvanized sheet metal
8 Connection spigot at box	
9 Volume flow damper (optional)	
10 Central fastener for radial outlet	
11 Suspension bracket	
12 Bore for suspension by others	
13 Threaded rod or quick fastener (by others)	
14 Adjustment device for volume flow damper	

Nom. $\varnothing$ DN	$D_2^{1)}$ mm	$H_3$ mm	RA-N2-RS			RA-N2-Q1		RA-N2-Q2		RA-N2-RS with reducer 'A'				
			$D_4$ mm	$H_6$ mm	W kg	$\square E^{2)}$ mm	W kg	$\square E^{2)}$ mm	W kg	$D_5$ mm	$H_1$ mm	$H_2$ mm	$H_4$ mm	W kg
250	302	44	375	26	1.7	595	3.4	620	3.7	179	150	110	74	2.3
280	338	46	420	26	2.0		3.5		3.8	199	155	115	76	2.7
315	380	52	470	29	2.5		3.6		3.9	223	169	129	82	3.4
355	428	57	530	32	3.1		3.7		4.0	249	201	141	87	4.2
400	482	63	600	35	3.8		3.8		4.1	279	213	153	93	5.1
450	542	73	675	41	4.7		4.1		4.3	314	231	171	103	6.3
500	602	78	750	45	6.0		—		—	—	—	354	241	181

<sup>1)</sup> Ceiling cutout

<sup>2)</sup> Other dimensions on request

<sup>3)</sup> Nominal diameters  $\geq \varnothing DN 355$  have a third suspension bracket at a 90° angle

# Radial outlet RA-N2

## Dimensions of connection types D and F

### Connection type D

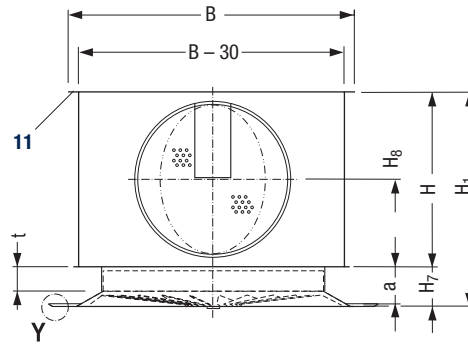
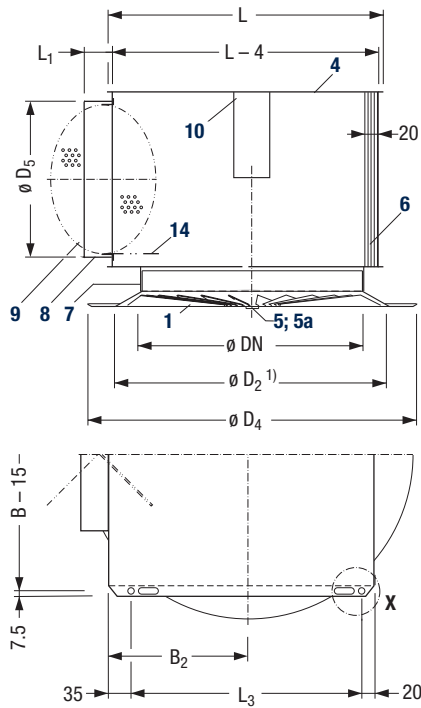

**Detail Y**  
RS - circular face  
Flush contact edge  
for ceiling attachment

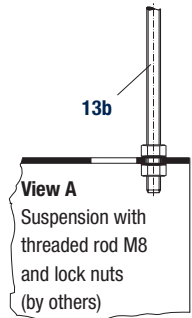
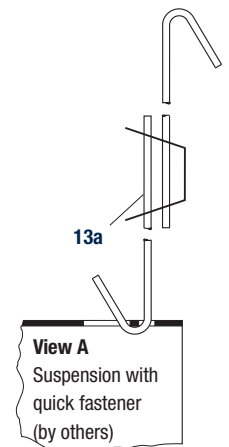

### Connection type F<sup>2)</sup>

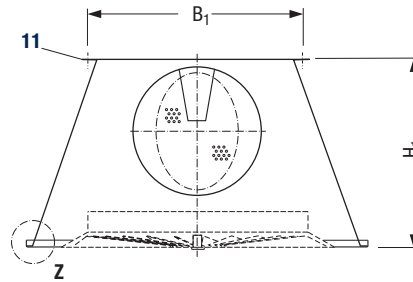
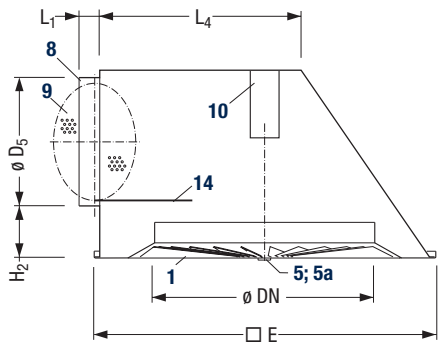

**Detail Z**  
Q1 and Q2 - square face  
90° turn-up for installation  
in square tile ceilings

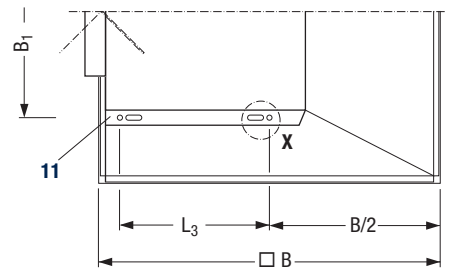
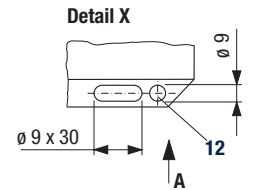

Nom. $\phi$ DN	Connection type D															Connection type F							
	$D_2^{1)}$ mm	$D_5$ mm	$L_1$ mm	L mm	B mm	$B_2$ mm	H mm	$H_1$ mm	$H_7$ mm	$H_8$ mm	$D_4$ mm	$L_3$ mm	a mm	t mm	W kg	$\square E^{3)}$ mm	$\square B$ mm	$B_1$ mm	$H_1$ mm	$H_2$ mm	$L_3$ mm	$L_4$ mm	$W^4)$ kg
250	302	179	40	315	330	165	205	256	51	103	375	260	47	35	5.9	595 620	388	289	248	56	160	223	6.5
280	338	199	40	345	360	180	225	278	53	113	420	290	49	35	7.0		388	278	268	56	160	210	6.9
315	380	223	40	380	395	198	250	307	57	125	470	325	53	35	8.5		488	360	302	66	210	287	8.4
355	428	249	60	420	435	218	275	337	62	138	530	365	58	35	10.4		488	346	328	66	210	269	8.8
400	482	279	60	465	480	240	305	373	68	153	600	410	64	40	12.6		588	424	368	76	260	342	10.6
450	542	314	60	515	530	265	340	418	78	170	675	460	74	40	15.4		588	405	403	76	260	319	11.2
500	602	354	60	565	580	290	380	463	83	190	750	510	79	45	18.6	—	—	—	—	—	—	—	—

1) Ceiling cutout

2) Connection box F for square face Q1 or Q2

3) Other dimensions on request

4) Weight inclusive of air outlet for  $\square E = 595$  mm

# Radial outlet RA-N2

## Comfort criteria and minimum air outlet centre spacing

### Comfort criteria <sup>1)</sup>

The outlet layout must comply with the maximum allowable indoor air velocities  $u$  in the occupied zone in the cooling mode. The indoor air velocity depends on the cooling load that is to be removed from the room. The maximum specific cooling capacity  $\dot{q}$  depends on the discharge height and the maximum allowable indoor air velocity  $u$  (Graph 1).

Graph 1 enables to determine for the cooling mode the maximum specific volume flow rate  $\dot{V}_{Sp\ max}$  in relation to the maximum specific cooling capacity and the maximum temperature difference  $\Delta\dot{\theta}_{max}$ . The volume flow rate supplied to the room  $\dot{V}_{Sp\ tats}$  may not exceed this value.

Graph 2 enables to determine the minimum centre spacing between two outlets on the basis of the maximum specific volume flow rate.

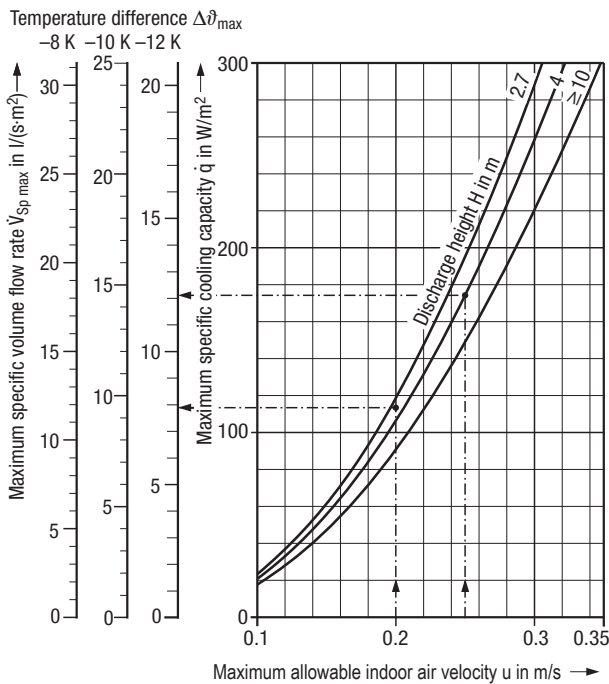

Graph 1: Maximum specific volume flow rate

### Key for layout:

- $\dot{V}_A$  = volume flow rate per air outlet in l/s
- $\dot{V}_{A\ max}$  = max. volume flow rate per air outlet when cooling in l/s
- $\dot{V}_{A\ min}$  = min. volume flow rate per air outlet when cooling in l/s
- $\dot{V}_{Sp\ max}$  = max. specific volume flow rate per m<sup>2</sup> of floor area in l/(s·m<sup>2</sup>)
- $\dot{V}_{Sp\ tats}$  = actual specific volume flow rate per m<sup>2</sup> of floor area in l/(s·m<sup>2</sup>)
- $u$  = max. allowable indoor air velocity in m/s
- $\dot{q}$  = max. specific cooling capacity in W/m<sup>2</sup>
- $\Delta\dot{\theta}_{max}$  = max. temperature difference supply air to return air in K
- $t_{min}$  = minimum air outlet centre spacing in m
- $H$  = discharge height in m
- $L_{WA}$  = sound power level in dB(A) ref. 10<sup>-12</sup> W
- $\Delta p_t$  = total pressure drop in Pa

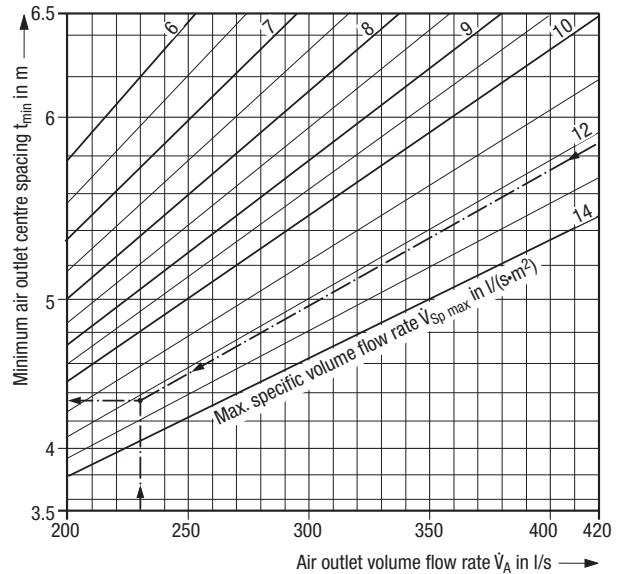
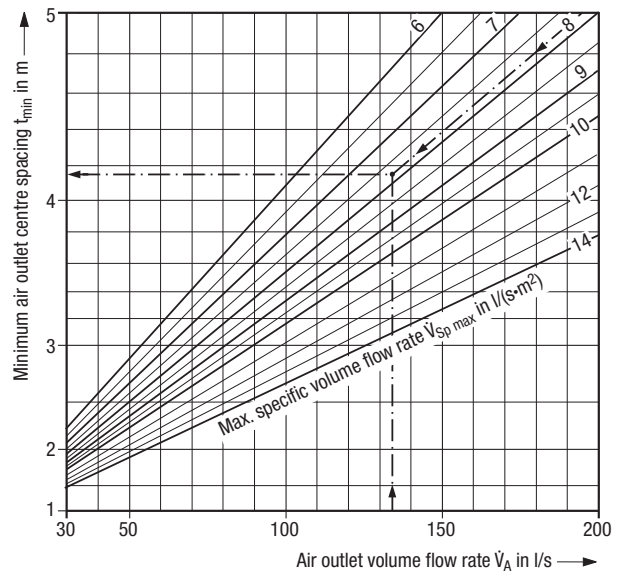

Graph 2: Minimum air outlet centre spacing

<sup>1)</sup> See our brochure ref. TB 69 'Layout specifications for thermal comfort'

# Radial outlet RA-N2

## Layout sheet

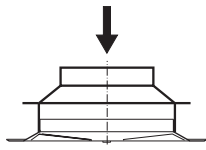

Connection type A

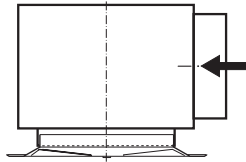

D and F

The diagram values for sound power level and pressure drop of connection types D and F apply to volume flow damper position 'open' and connection box without acoustic lining. With acoustic lining the sound power level is approx. 2 dB(A) lower than mentioned in the diagram. The pressure drop is not influenced by the acoustic lining.  $\dot{V}_{A \text{ min}}$  applies to the freely suspended design.

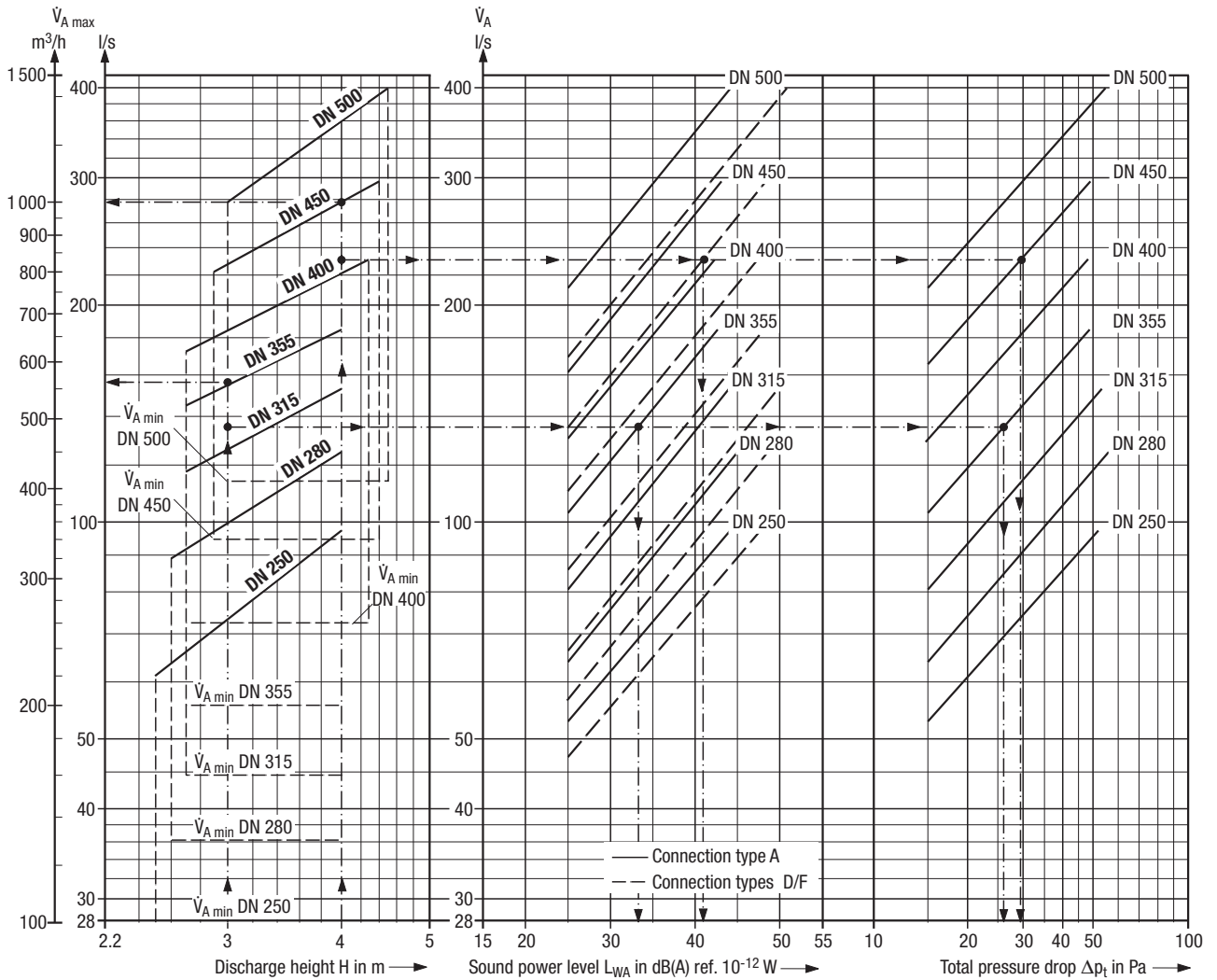

Layout examples			
Size		DN 355	DN 450
Connection type		A	F
Application		Office	Department store
1 Supply air volume flow rate $\dot{V}$	l/s	670	5 550
2 Discharge height H	m	3	4
3 Floor area A	m <sup>2</sup>	120	1 200
4 Max. allowable sound power level $L_{WA}$	dB(A) ref. 10 <sup>-12</sup> W	40	45
5 Temperature difference $\Delta \vartheta_{\text{max}}$	K	-12	-12
6 Comfort criteria (see page 6)			
- Max. allowable indoor air velocity u	m/s	0.2	0.25
- Max. specific volume flow rate $\dot{V}_{Sp \text{ max}}$	l/(s · m <sup>2</sup> )	7.8	12.2
- Actual specific volume flow rate [from 1 : 3] $\dot{V}_{Sp \text{ tats}}$	l/(s · m <sup>2</sup> )	5.6	4.6
Criterion is met if $\dot{V}_{Sp \text{ tats}} < \dot{V}_{Sp \text{ max}}$			

From nomogram			
Size		DN 355	DN 450
7 $\dot{V}_{A \text{ max}}$	l/s	155	278
8 Z	$[\geq \dot{V} : \dot{V}_{A \text{ max}}]$	5	24
9 $\dot{V}_A$	$[\dot{V} : Z]$	134	230
10 $L_{WA}$	dB(A) ref. 10 <sup>-12</sup> W	33	41
11 $\Delta p_t$	Pa	26	30
12 $t_{\text{min}}$	[Graph 2, p. 6]	≈ 4.1	≈ 4.3

# Radial outlet RA-N2

## Sound power level and insertion loss of RA-N2 used as supply air outlet

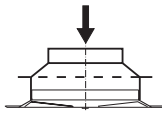

Connection type A

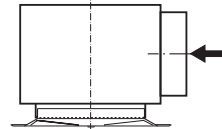

Connection types D and F

Size	Connection type A										Connection types D and F									
	Air outlet volume flow rate $\dot{V}_A$		Total pressure drop $\Delta p_t$	Sound power level $L_{WA}$	Sound power level $L_W$ in dB ref. $10^{-12}$ W						Air outlet volume flow rate $\dot{V}_A$		Total pressure drop $\Delta p_t$	Sound power level $L_{WA}$	Sound power level $L_W$ in dB ref. $10^{-12}$ W					
	Pa	dB(A)			Octave band centre frequency in Hz						Pa	dB(A)			Octave band centre frequency in Hz					
			125	250	500	1 K	2 K	4 K	125	250			500	1 K	2 K	4 K				
DN 250	53	1 90	15	25	27	28	26	15	—	—	46	165	10	25	27	30	24	11	—	—
	72	260	28	35	36	36	35	30	10	—	65	235	19	35	41	39	34	28	15	—
	100	360	55	45	42	42	42	43	30	14	92	330	38	45	48	46	41	42	33	17
DN 280	64	230	15	25	28	28	26	13	—	—	56	200	10	25	28	32	22	—	—	—
	89	320	29	35	36	36	35	29	10	—	78	280	20	35	37	39	35	23	12	—
	125	450	56	45	43	42	43	43	29	15	111	400	41	45	47	49	45	38	28	12
DN 315	81	290	15	25	28	28	26	11	—	—	67	240	9	25	32	30	24	10	—	—
	111	400	29	35	37	36	36	28	11	—	94	340	19	35	41	40	35	23	—	—
	158	570	57	45	43	42	43	43	28	15	131	470	37	45	48	48	43	40	30	13
DN 355	103	370	15	25	28	28	26	—	—	—	83	300	9	25	31	31	23	14	—	—
	144	520	29	35	37	37	36	27	11	—	115	415	19	35	40	40	33	28	10	—
	200	720	57	45	44	42	44	42	28	16	167	600	38	45	48	47	42	41	32	15
DN 400	131	470	15	25	30	29	26	—	—	—	108	390	9	25	32	30	24	—	—	—
	184	660	30	35	38	37	36	27	12	—	150	540	20	35	41	39	34	27	10	—
	253	910	58	45	45	43	44	42	29	17	244	760	37	45	50	48	43	40	27	11
DN 450	161	580	14	25	32	29	25	10	—	—	136	490	9	25	33	31	22	—	—	—
	228	820	28	35	40	37	35	26	14	—	186	670	19	35	42	39	35	25	13	—
	317	1 140	55	45	45	44	44	41	31	18	267	960	37	45	50	48	44	39	29	14
DN 500	211	760	15	25	33	28	23	—	—	—	169	610	9	25	33	29	25	—	—	—
	294	1 060	30	35	40	37	35	25	15	—	236	850	18	35	42	38	36	24	10	—
	411	1 480	58	45	46	45	44	40	32	20	331	1 190	39	45	48	45	45	39	28	13

Insertion loss in dB						
Size	Connection box <b>without</b> acoustic lining					
	Octave band centre frequency in Hz					
DN	125	250	500	1 K	2 K	4 K
250	4	2	4	5	3	2
280	4	2	4	5	3	2
315	4	2	4	5	4	3
355	4	2	5	5	4	3
400	4	2	4	4	3	3
450	4	2	3	3	3	2
500	4	2	2	3	2	2

Insertion loss in dB						
Size	Connection box <b>with</b> acoustic lining					
	Octave band centre frequency in Hz					
DN	125	250	500	1 K	2 K	4 K
250	4	2	5	8	6	7
280	4	2	5	7	6	8
315	4	2	6	7	6	7
355	4	2	6	6	5	6
400	4	2	5	6	4	5
450	4	2	5	6	4	4
500	4	2	5	6	4	4



# Radial outlet RA-N2

## Sound power level of RA-N2 used as return air inlet

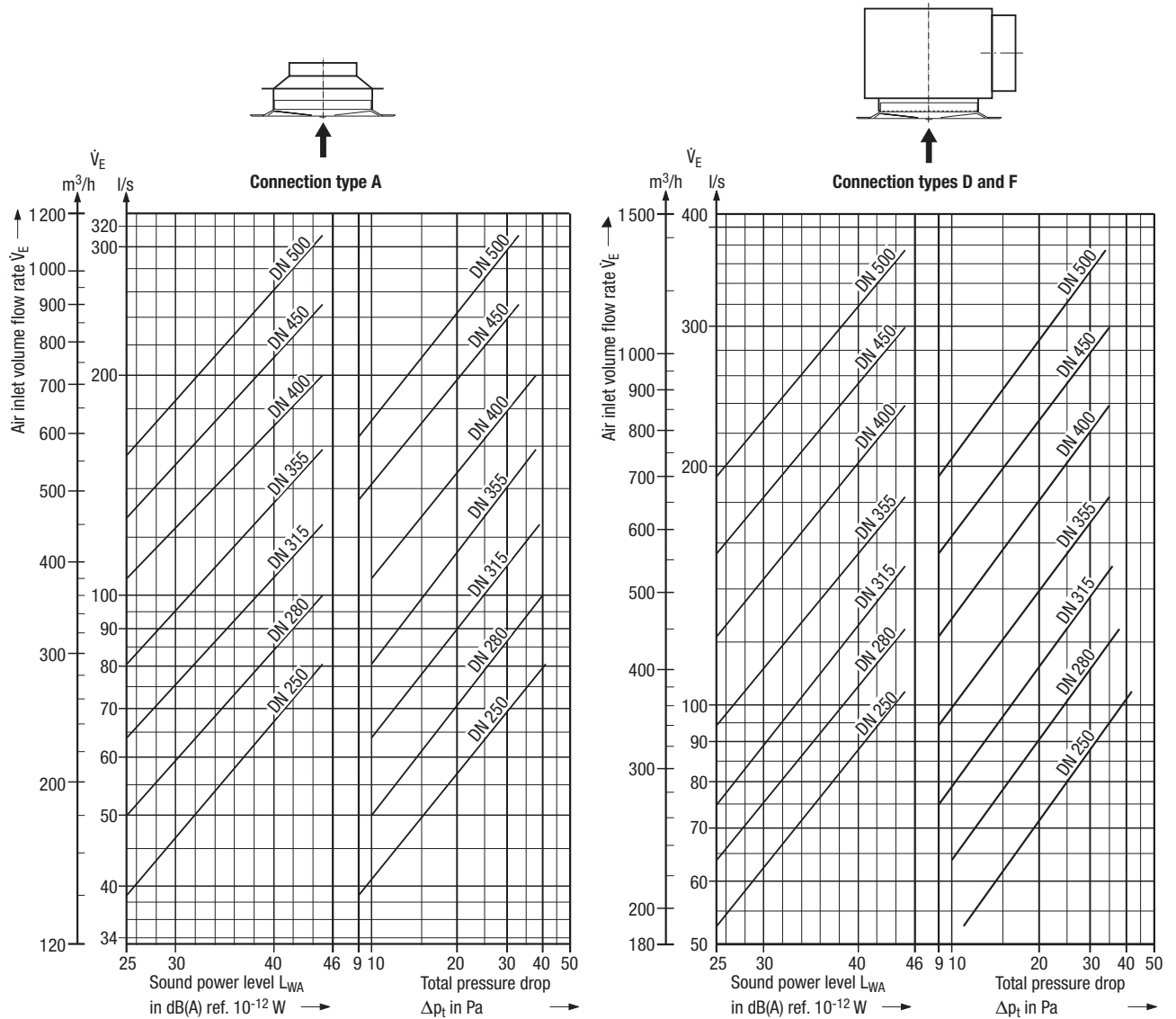

Size	Connection type A										Connection types D and F									
	Air inlet volume flow rate $\dot{V}_E$		Total pressure drop $\Delta p_t$ Pa	$L_{WA}$ dB(A)	Sound power level $L_{Wj}$ in dB ref. $10^{-12}$ W						Air inlet volume flow rate $\dot{V}_E$		Total pressure drop $\Delta p_t$ Pa	$L_{WA}$ dB(A)	Sound power level $L_{Wj}$ in dB ref. $10^{-12}$ W					
	l/s	$m^3/h$			125	250	500	1 K	2 K	4 K	l/s	$m^3/h$			125	250	500	1 K	2 K	4 K
DN 250	39	140	9	25	26	28	25	16	—	—	53	190	11	25	31	30	23	13	—	—
	56	200	19	35	31	36	34	30	20	—	72	360	20	35	38	37	29	34	14	—
	81	290	41	45	37	49	41	42	37	24	104	375	42	45	47	45	40	42	36	20
DN 280	50	180	10	25	26	27	25	17	—	—	64	230	10	25	32	30	23	13	—	—
	69	250	19	35	32	36	34	31	21	—	89	320	19	35	39	37	30	32	14	—
	100	360	40	45	38	46	41	41	37	24	125	450	38	45	47	45	39	43	35	19
DN 315	64	230	10	25	26	26	25	19	—	—	75	270	9	25	32	30	23	13	—	—
	89	320	20	35	33	35	34	31	23	—	108	390	19	35	41	38	31	31	16	—
	125	450	39	45	38	44	41	42	37	25	150	540	36	45	48	45	38	43	33	19
DN 355	81	290	10	25	25	25	25	20	—	—	94	340	9	25	33	30	23	13	—	—
	114	410	20	35	33	34	34	31	24	—	133	480	18	35	42	39	32	30	17	—
	158	570	38	45	39	41	41	42	38	25	183	660	35	45	48	44	37	44	31	18
DN 400	106	380	10	25	27	25	25	19	—	—	122	440	9	25	33	29	24	13	—	—
	144	520	20	35	33	33	34	31	24	—	172	620	19	35	42	38	33	30	17	—
	200	720	38	45	40	41	41	42	38	24	239	860	35	45	48	43	38	44	31	19
DN 450	128	460	8	25	28	26	25	19	—	—	156	560	9	25	33	28	25	12	—	—
	181	650	20	35	34	33	34	31	24	—	217	780	19	35	41	36	33	30	17	—
	250	900	33	45	41	40	41	41	39	24	300	1080	35	45	47	42	38	44	31	20
DN 500	156	560	8	25	29	26	25	18	—	—	194	700	9	25	32	26	25	11	—	—
	219	790	16	35	35	32	34	31	24	—	269	970	19	35	41	35	34	30	17	—
	311	1120	33	45	42	40	41	41	39	24	375	1350	34	45	48	43	40	45	32	22

# Radial outlet RA-N2

## Features

- For high-quality diffuse indoor air flow
- Discharge height from 2.5 to 4.5 m depending on outlet size
- Maximum temperature difference between supply air and indoor air:  
–12 K when cooling, +5 K when heating (+10 K up to 3 m room height)
- Low sound power level
- Stable supply air jets, even at minimum volume flow rate
- For installation flush with ceiling, above open grid or expanded metal ceilings, or freely suspended from the ceiling
- Outlet element mountable from room side
- Available with circular or square face
- Outlet element made of powder coated sheet metal, connection box made of galvanized sheet metal
- Low construction height
- Combinable with reducer or connection box
- Optional volume flow damper adjustable from room side
- Optional acoustic lining
- Can be used as return air inlet, regardless of connection type

## Tender text

..... units

Radial outlet for high-quality indoor air flow with minimal temperature gradient in the occupied zone,

consisting of:

radial outlet element in low construction design with spigot and radial vanes – vane undersides flush with surrounding face area –, either with circular face for ceiling attachment or with square face with all-side turn-up for installation in a square tile ceiling, and with central fastening screw with cap;

connection to the duct system either via a reducer fitted with lateral suspension brackets and connection for the central fastener of the outlet, or via a connection box with connection spigot for circular outlet or a connection box for square outlet,

## Type code

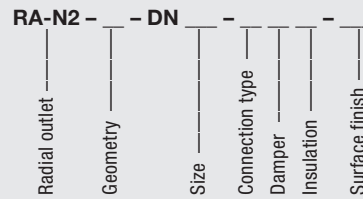

### Geometry

- RS = circular face  
Q1 = square face for square tile ceiling 600 mm x 600 mm  
Q2 = square face for square tile ceiling 625 mm x 625 mm

### Size

- |              |              |
|--------------|--------------|
| 250 = DN 250 | 400 = DN 400 |
| 280 = DN 280 | 450 = DN 450 |
| 315 = DN 315 | 500 = DN 500 |
| 355 = DN 355 |              |

### Connection type

- 0 = no connection piece (only outlet element)  
A = reducer (connection type A)  
D = connection box (connection type D), external sleeve  
F = connection box (connection type F), for square face

### Damper

- 0 = no volume flow damper  
R = with volume flow damper adjustable from room

### Insulation

- 0 = without acoustic lining  
I = with acoustic lining (connection type D)

### Surface finish

- 9010 = face painted to RAL 9010, semi-matt  
.... = face painted to RAL ....

with central fastener for fixing the outlet and flange bores for suspension; optional volume flow damper adjustable from room side; optional acoustic lining (only for connection type D).

Materials:

- Radial outlet made of galvanized sheet metal, powder coated to RAL 9010, pure white, or RAL ....
- Reducer made of aluminium
- Connection box made of galvanized sheet metal

Make: KRANTZ KOMponentEN  
Type: RA-N2 – – – DN – – – – –

Subject to technical alterations.