

Technical Selection

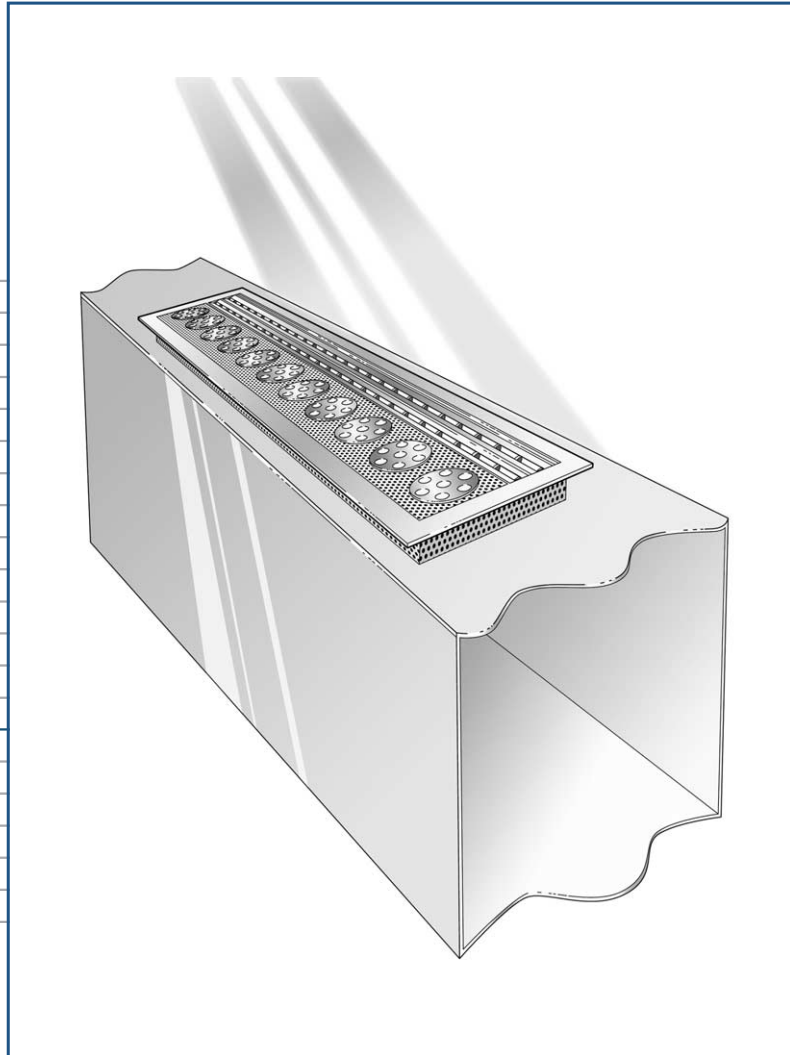

Parapet outlet BL-V....

Preliminary remark

In many cases conventional air grilles of fan coil units discharge the supply air at a too steep upward incline; this may generate tangential air patterns with high indoor air velocities that will cause thermal discomfort.

Further, these air grilles are not adjustable, i.e. the room occupants cannot adapt the air discharge direction or jet spread to their own requirements.

KRANTZ KOMPONENTEN has developed the parapet outlet specially for installation in the existing cover of a window parapet, above a fan coil unit or a pressurized duct.

The parapet outlet provides two types of adjustable jet: a vertical jet for facade screening and a jet inclined towards the room. The parapet outlet combines the proven components of the induction outlet and the multiplex outlet from KRANTZ KOMPONENTEN.

In a number of cases it is easy to replace the existing air grilles with parapet outlets.

Application and outlet data

- For ventilation of workplaces close to the facade
- Recommended minimum distance between outlet and workplace: ≥ 0.8 m
- Max. temperature difference between supply air and indoor air: +10 K when heating, -10 K when cooling
- Max. supply air volume flow rate: 128 l/(s · m) [460 m³/(h · m)]
- Cooling load to be removed: max. 1 550 W/m at -10 K, 70 – 80 W/m² in commercial applications
- For room depths up to 8 m
- Coverage width up to 3 times the outlet length
- Low sound power level
- Low pressure loss, thus easy to combine with fan coil units

Air outlet length L_A mm	Volume flow rate range				max. temperature difference supply air–indoor air	
	\dot{V}_{min}		\dot{V}_{max}		Cooling mode K	Heating mode K
	l/s	m ³ /h	l/s	m ³ /h		
800	33	120	103	370	- 10	+ 10
1 025	42	150	131	470		
1 250	53	190	161	580		
1 550	67	240	200	720	- 8	

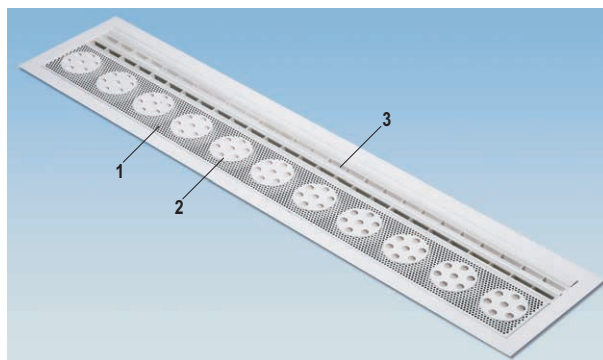

Fig. 1: Parapet outlet

Mode of operation

The supply air is discharged at low turbulence through the perforations of the frontal plate **1** and is induced and guided by both the jet bundle elements **2** and the induction elements **3**.

The inclination of the air discharge elements is factory-set, but the room occupants can reset individual elements as they like.

The jet bundle elements discharge the air at a certain incline. By rotating individual elements, the room occupants can let more or less air to the opposite room side or spread the air jets laterally.

By turning individual induction elements (each 75 mm long), the air jet discharged along the facade can be bundled, spread out, or partly directed to the room inside.

The air flow generated by the parapet outlet is a combination of turbulent mixing air flow (facade screening) and air flow similar to displacement flow at floor level (workplace ventilation).

At typical ceiling heights of 2.7 to 4 m the vertical supply air jet induces indoor air at a high ratio. Thus, the jet velocity and the temperature difference between supply air and indoor air decrease rapidly. In summer, the heat gain resulting from transmission is efficiently offset by cooled supply air. In winter, the vertical heated air curtain prevents cold air drop along the facade.

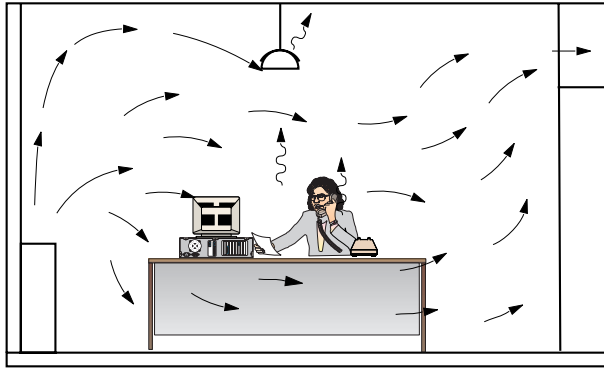

Fig. 2: Air upflow along the facade and air flow into the room, made visible by a sketch and smoke tracer

In particular in rooms where not every facade axis is fitted with fan coil units, the jet bundle elements allow for lateral distribution of supply air and thus more efficient ventilation of workplaces.

Construction design

The parapet outlet is 202 mm in width and is available in the following lengths L_A : 800, 1025, 1250, and 1550 mm. The frontal plate **1** of the outlet has perforations and incorporates adjustable jet bundle elements **2** and induction elements **3** whose inclination is factory-set according to usual applications.

The apertures of the jet bundle elements are at an angle to the discharge plane (see dimensioned sketch). By rotating individual elements, the room occupants can adapt the jet direction to their personal needs.

The 2-row induction elements can also be turned individually. This way, the air jet discharged along the window or facade can be bundled, spread out, or partly directed to the room inside.

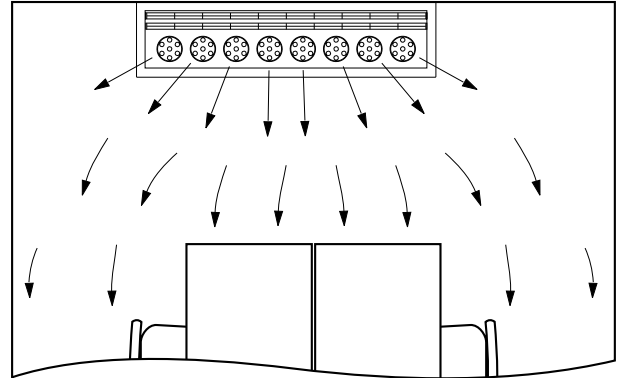

Fig. 3: View towards the facade, air flow made visible by a sketch and smoke tracer

Key

- | | |
|-----------------------------------|----------------------|
| 1 Frontal plate with perforations | 3 Induction elements |
| 2 Adjustable jet bundle elements | 4 Frame |

The parapet outlet will be inserted into the opening of the parapet cover where it will be supported by the frame **4**.

The frontal plate and the frame are made from sheet metal powder-coated to RAL, the jet bundle elements and the induction elements are made from white or black plastic resistant to UV light.

In many cases it is very easy to replace simple air grilles with parapet outlets from KRANTZ KOMPONENTEN.

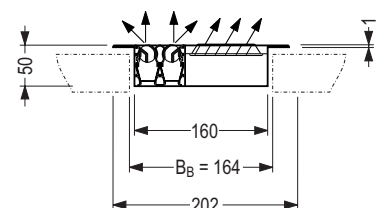
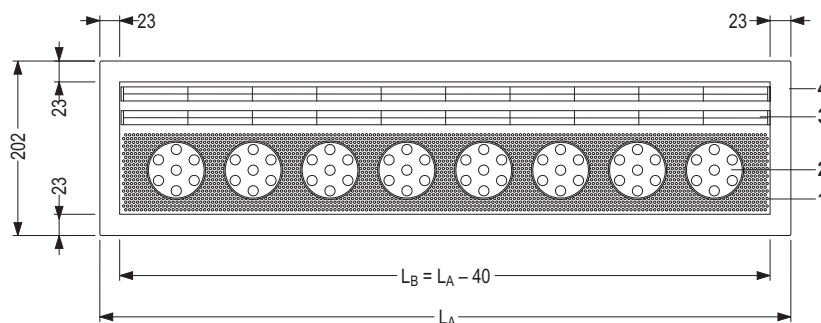

Comfort criteria

The layout of the outlet is based on compliance with the required maximum permissible indoor air velocities. The requisite minimum air outlet centre spacing L_{min} is dependent upon the room height and the maximum specific volume flow rate $\dot{V}_{Sp\ max}$ and can be determined using the following graph and equations.

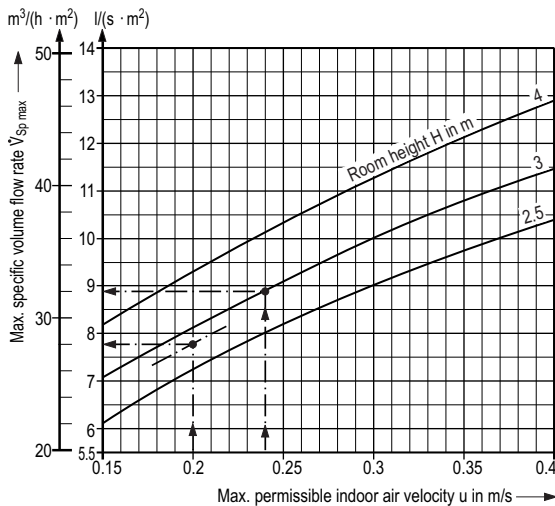

Key for pages 4 and 5

- \dot{V}_A = Supply air volume flow rate per parapet outlet
- $\dot{V}_{A\ max}$ = max. volume flow rate per parapet outlet
- $\dot{V}_{A\ gew}$ = Selected volume flow rate taking account of permissible sound pressure level
- $\dot{V}_{Sp\ max}$ = max. specific volume flow rate per m^2 of floor area
- u = max. permissible indoor air velocity in m/s
- E = Coverage width
- L_E = Coverage length
- L_{min} = min. air outlet spacing
- L_A = Air outlet length

Coverage width and minimum spacing

The coverage width E and the minimum air outlet spacing L_{min} can be determined on the basis of the maximum specific volume flow rate $\dot{V}_{Sp\ max}$ and the coverage length L_E (see layout examples on page 5):

$$E = \frac{\dot{V}_A}{\dot{V}_{Sp\ max} \cdot L_E} \quad E - L_A > L_{min}$$

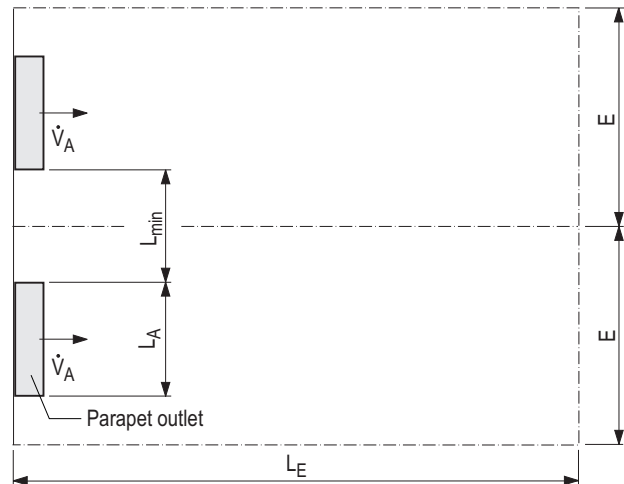
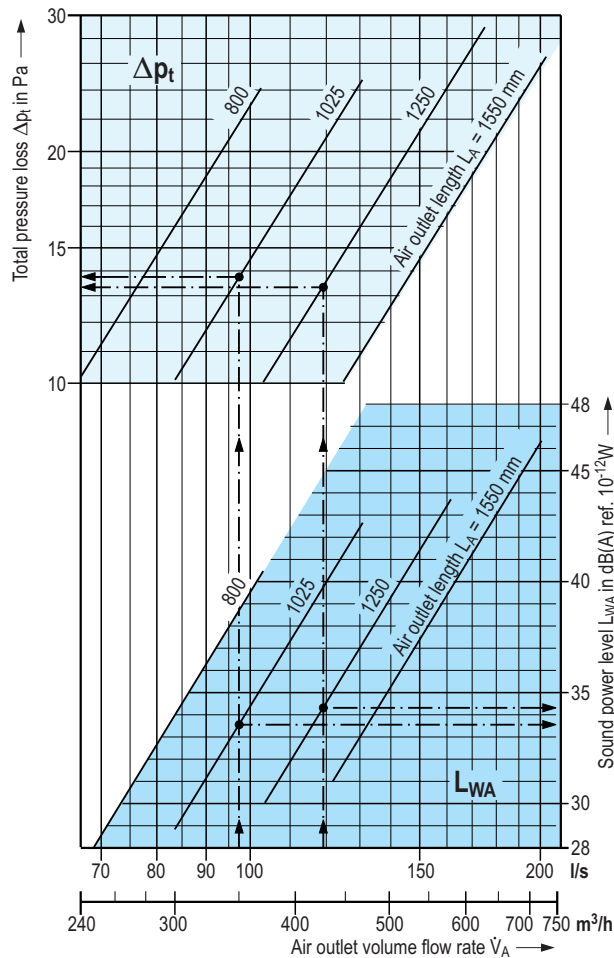

Fig. 4: Coverage width E , coverage length L_E and minimum spacing L_{min}



Fig. 5: Parapet outlet in an airport tower (Belgocontrol in Brussels)



Air outlet length L_A mm	Volume flow rate \dot{V}_A		Total pressure loss Δp_t Pa	Sound power level in dB ref. $10^{-12}W$						
	l/s	m^3/h		L_{WA} dB(A)	Octave band centre frequency in Hz					
					125	250	500	1 K	2 K	4 K
800	69	250	11	28	25	29	28	23	10	—
	76	275	13	31	28	30	31	26	18	—
	83	300	16	34	29	33	33	30	23	—
	97	350	22	39	32	35	37	36	29	13
1025	83	300	10	30	30	29	30	26	10	—
	97	350	14	34	33	31	33	31	18	—
	111	400	18	38	36	35	37	35	23	—
	125	450	23	41	38	37	39	38	31	16
1250	111	400	12	32	33	30	32	28	15	—
	125	450	15	36	35	33	35	33	20	—
	139	500	18	39	37	36	38	36	26	10
	160	575	24	43	40	39	41	40	33	19
1550	139	500	12	35	34	33	35	31	17	—
	153	550	15	38	37	34	37	35	22	—
	181	650	21	43	41	40	41	40	32	15
	200	720	26	46	44	43	45	41	38	25

Layout example

Office space
12 facade axes, 1.35 m each, every third axis fitted with parapet outlets
Room depth = 6 m
Room height = 2.7 m
Permissible sound power level = 35 dB(A) ref. $10^{-12}W$
Max. permissible indoor air velocity $u \leq 0.2$ m/s
Total volume flow rate = 390 l/s

- 1 From 'comfort criteria' diagram on page 4: $\dot{V}_{Sp \max} = 7.8$ l/(s · m²)
- 2 Volume flow rate per parapet outlet 390 l/s : $4 = 97$ l/s = \dot{V}_A
- 3 Selected outlet length $L_A = 1025$ mm
- 4 Coverage length equals room length, $L_E = 6$ m
- 5 Coverage width $E = \frac{\dot{V}_A}{\dot{V}_{Sp \max} \cdot L_E} = \frac{97}{7.8 \cdot 6} = 2.07$ m
- 6 $L_{\min} = E - L_A = 2.07 - 1.025 = 1.05$ m
The spacing available $3 \cdot 1.35 - 1.025 = 3.025$ is sufficient.
- 7 $L_{WA} \approx 33.5$ dB(A) ref. $10^{-12}W$, $\Delta p_t \approx 14$ Pa from above nomogram
- 8 $L_{WA} < L_{WA \text{ permissible}}$

Layout example

Restaurant
20 facade axes, 2.5 m each, fitted with parapet outlets
Room depth = 8 m
Room height = 3 m
Permissible sound power level = 40 dB(A)
Max. permissible indoor air velocity $u \leq 0.24$ m/s
Total volume flow rate = 2360 l/s

- 1 From 'comfort criteria' diagram on page 4: $\dot{V}_{Sp \max} = 8.9$ l/(s · m²)
- 2 Volume flow rate per parapet outlet 2360 l/s : $20 = 118$ l/s = \dot{V}_A
- 3 Selected outlet length $L_A = 1250$ mm
- 4 Coverage length equals room length, $L_E = 8$ m
- 5 Coverage width $E = \frac{\dot{V}_A}{\dot{V}_{Sp \max} \cdot L_E} = \frac{118}{8.9 \cdot 8} = 1.66$ m
- 6 $L_{\min} = E - L_A = 1.66 - 1.25 = 0.41$ m
The spacing available $2.5 - 1.25 = 1.25 > 0.41$ is sufficient.
- 7 $L_{WA} \approx 34$ dB(A) ref. $10^{-12}W$, $\Delta p_t \approx 13$ Pa from above nomogram
- 8 $L_{WA} < L_{WA \text{ permissible}}$

Features

- Air outlet generating turbulent mixing air flow, for placement in covers of window parapets
- For combination with a fan coil unit or a pressurized duct
- Rapid decrease in jet velocity and temperature difference supply air–indoor air resulting from the spreading of supply air discharged by adjustable jet bundle and induction elements
- Coverage width up to 3 times the outlet length
- Facade screening thanks to vertical air jet discharged by induction elements
- At workplaces close to the window, the room occupants can adjust the jet bundle elements to suit their personal needs
- Basic setting of both induction and jet bundle elements made at factory
- For rooms up to 8 m in depth and 4 m in height
- High cooling capacity, up to 2000 W per outlet
- High specific air volume flow rate: up to 128 l/(s · m) [460 m³/(h · m)]
- Low temperature gradient across room height: < 2 K/m
- Low sound power level
- 4 lengths available: 800, 1025, 1250, and 1550 mm
- Perforated frontal plate and frame made of powder-coated sheet metal
- Induction and jet bundle elements made of plastic resistant to UV light, body-tinted in white similar to RAL 9010 or black similar to RAL 9005
- Best suited for replacing existing air grilles so as to improve the indoor air flow

Type code

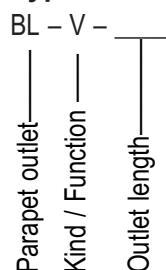

Kind / Function

V = adjustable

Outlet length

800, 1025, 1250 and 1550 [mm]

Tender text

.... units

Parapet outlet designed for placement in the existing cover of a window parapet, above a fan coil unit or a pressurized duct. Two types of adjustable jet: a vertical jet for facade screening and a jet inclined towards the room for direct room ventilation. Supply air spreading with rapid jet velocity decrease, thus no uncomfortable tangential air patterns.

Outlet consisting of:

frontal plate with perforations and built-in jet bundle elements as well as 2-row induction outlet with adjustable induction elements, and frame. Each jet bundle element can be manually rotated by 360°.

Material:

- Jet bundle and induction elements: ABS resistant to UV light, body-tinted in pure white similar to RAL 9010 or jet-black similar to RAL 9005
- Perforated frontal plate and frame: galvanized sheet metal powder-coated to RAL 9010 or similar to RAL

Dimensions of frontal plate:

- Outlet length L_A :
- 800 mm¹⁾
 - 1025 mm¹⁾
 - 1250 mm¹⁾
 - 1550 mm¹⁾
- Outlet width B: 202 mm¹⁾

Make: KRANTZ KOMPONENTEN

Type: BL – V – ____

– Subject to technical alteration –

¹⁾ Length and width of frame can be made bigger upon request